

MONESSEN HEARTH SYSTEMS

BWB400, BWB400I, BWBC400 AND BWBC400I WOOD BURNING FIREPLACES INSTALLATION, OPERATION AND MAINTENANCE MANUAL

BWB400-SERIES (RADIANT TYPE)

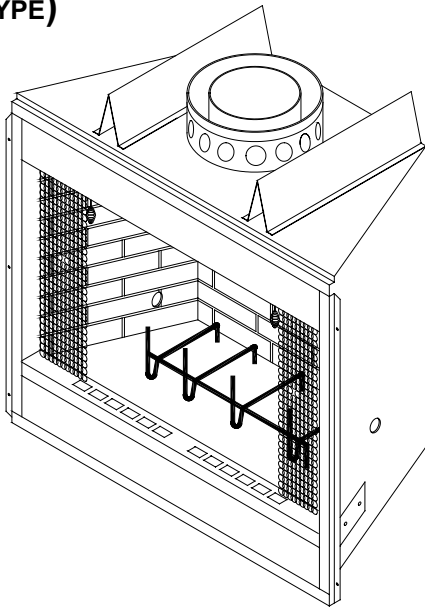

36 INCH BUILT-IN WOOD BURNING FIREPLACES.
(GLASS DOORS, FAN ASSEMBLY, AND OUTSIDE
COMBUSTION AIR KIT AVAILABLE.)

BWBC400- SERIES (CIRCULATING TYPE)

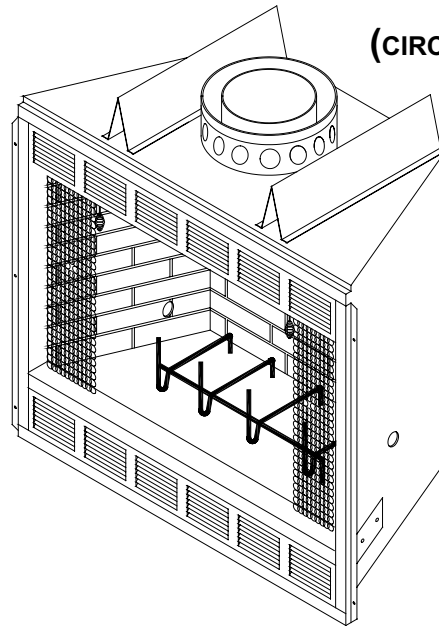

THESE FIREPLACES ARE U. L.[®] LISTED FOR USE
WITH "S" SERIES CHIMNEY SYSTEM COMPONENTS.

ONLY MODELS DYS24/18(N,P)(M,V) UNVENTED GAS LOG SETS WHICH HAVE BEEN FOUND TO COMPLY WITH THE STANDARD FOR UNVENTED ROOM HEATERS ANSI Z21.11.2, ARE TO BE INSTALLED IN THIS FIREPLACE. 075629 HOOD MUST BE INSTALLED WHEN MANTLE IS INSTALLED AT 12" FROM FIREPLACE OPENING.

TABLE OF CONTENTS

CONGRATULATIONS!

You have chosen the finest wood burning fireplace available. Your fireplace has been designed for years of heating and viewing enjoyment. Please take time to read this entire manual before installing or operating your fireplace.

Listing and Code Approvals	2
Important Information	3
Operation Guidelines	4
Clearances	5
Fireplace Location	7
Installation Preparation	8
Floor Protection	10
Fireplace Components	12
Fireplace Installation	14
Chimney Installation	15
Chimney Offset Installation	17
Chimney Cap Installation	18
Chimney Cap Chase Installation	21
Outside Combustion Air Precautions and Recommendations	22
Combustion Air Assembly	24
Gas Appliance Installation	24
Trim Installation	26
Glass Door Installation and Fan Accessory	28
Fireplace Operation	29
Maintenance and Safety Instructions.....	31
Parts Diagrams and Lists.....	34
Warranty	36

LISTING AND CODE APPROVALS

The instructions contained in this manual provide the information necessary to install this fireplace in accordance with Underwriter's Laboratories requirements and in compliance with the National Fire Protection Association Standard No. 211. Some codes may require the fireplace and chimney be electrically grounded. Before beginning the installation, you should check with local building officials to obtain required permits and assure compliance with local regulations and codes. If you encounter problems with code requirements, contact your dealer for assistance.

This fireplace is listed by Underwriters Laboratories to U.L. 127 standard for factory-built fireplaces. The design of this fireplace and these instructions complied with applicable safety standard for a factory built fireplace in effect at the time the fireplace was manufactured. You should be aware, however, that failure to install, operate, and maintain this or any other factory built fireplace properly can result in a house fire or other occurrences that could cause deaths, injuries, and property damages. It is very important that the persons installing and/or supervising the installation of this fireplace have appropriate skills in using the tools and techniques required; and reading and comprehension skills sufficient to read and follow these instructions. These instructions contain warnings, cautions, and notes to emphasize important safety information. To assure that safe and satisfactory service is received from this fireplace, please read the following special notices and all the contents of this manual.

IMPORTANT INFORMATION

1. Read these instructions entirely before beginning any part of the installation. Save these instructions for any future repairs.
2. Use these instructions as a guide during the installation of the fireplace.
3. Be sure these instructions become the property of and are reviewed by all future users of this fireplace to encourage proper operation and maintenance.
4. All the parts used with this fireplace system must be installed in accordance with these installation instructions. Failure to do so may be hazardous and will void the warranty.
5. This fireplace and accessories should not be altered in any way that is not specifically recommended in this manual.
6. Refer to your local building code for local requirements pertaining to installation of factory-built fireplaces. Monessen Hearth Systems fireplaces are intended for installation and use according to standard NFPA 211 of the National Fire Protection Association.
7. This fireplace must not be installed with a masonry flue.
8. This fireplace and chimney should not be used for venting a wood or coal burning heater or fireplace insert.
WARNING: DO NOT INSTALL A SEPARATE SOLID FUEL INSERT OR GAS FIREPLACE INSERT IN THIS FIREPLACE AND CHIMNEY SYSTEM WITHOUT WRITTEN AUTHORIZATION FROM **MONESSEN HEARTH SYSTEMS**.
9. Do not pack required air spaces with combustible material or insulation not specifically recommended for use in such areas.

INTENDED PRODUCT USAGE

This fireplace is intended for supplemental heating only and is not intended for use as a primary heating system.

This fireplace is designed to sit directly on a combustible floor. The fireplace must be installed with clearances to combustible building materials as specified by this manual. Only parts manufactured by Monessen Hearth Systems and labeled for use with this fireplace should be used in the installation of the fireplace except for special roof flashings that may be fabricated locally. The use of improper parts in the installation can be hazardous and voids the warranty offered by Monessen Hearth Systems.

This fireplace is designed to burn solid wood fuel (wood), UL-classified processed solid fuel fire logs, or a certified decorative gas appliance may be installed in the fireplace as described later by this instruction manual.

This fireplace is not designed to burn coal, unplumbed liquid fuels, unplumbed gaseous fuels or household refuse. Any attempt to burn these fuels in the fireplace can be hazardous.

NOTICE: *THIS FIREPLACE IS NOT DESIGNED FOR INSTALLATION IN MANUFACTURED HOMES WITHOUT A VENTED ATTIC SPACE. THE FIREPLACE MAY BE INSTALLED IN MANUFACTURED HOMES WHICH HAVE A VENTED ATTIC SPACE IF THE FIREPLACE IS EQUIPPED WITH **GD36B** OR **GD36PB** GLASS DOORS, AN **AK6** OUTSIDE COMBUSTION AIR KIT (INSTEAD OF THE **AK4** OUTSIDE COMBUSTION AIR KIT OFFERED FOR RESIDENTIAL TYPE HOMES AS DESCRIBED LATER BY THIS INSTRUCTION MANUAL), A **SVTR** FIRESTOP THIMBLE, AND THE MINIMUM INSTALLED HEIGHT FROM FLOOR TO FLUE OUTLET IS **14 FEET**. SEE FIGURE 1.*

CAUTION: DO NOT USE A FIREPLACE INSERT OR OTHER PRODUCT NOT SPECIFIED FOR USE WITH THIS FIREPLACE.

WARNING: IMPROPER INSTALLATION OR USE OF THIS FIREPLACE WILL VOID ITS WARRANTY AND CAN CAUSE:

1. **Damage to the fireplace from overheating.**
2. **Hazardous temperatures to develop on combustible materials adjacent to the fireplace or chimney.**
3. **The emission of smoke, sparks or hazardous gases into the dwelling.**
4. **Leakage of rain water into the dwelling.**

OPERATION GUIDELINES

As wood is burned in the fireplace, room air entering the fireplace is circulated around the fireplace firebox. This air circulation protects the firebox from overheating. Air circulation through the fireplace must not be blocked or restricted in any manner. Blocking or restricting air circulation through the fireplace can cause a fire hazard.

In residential type installation, an AK4 outside combustion air kit may be connected to the left side of the fireplace to allow outside air to enter the firebox through a dampered opening in that side of the fireplace. This “outside combustion air” feature reduces the room air used for combustion and prevents excessive heat loss from the room. When the fireplace is in use, the fireplace’s “outside combustion air” damper connected to an AK4 may be opened to allow air from outside to enter the fireplace firebox. When the fireplace is not in use, the “outside combustion air” damper should be closed to prevent cold air from entering the firebox. An “outside combustion air” damper is open when its control lever is up, and closed when its control lever is down. A control lever for the “outside combustion air” damper is located inside the firebox near the top of the side firebrick on the left side of the fireplace. The design of the fireplace allows the routing of the combustion air duct downward or horizontally to obtain the outside combustion air; this permits flexibility in planning your installation. See Figures 24 thru 27 and their instructions for typical installation of outside combustion air kits. Review the precautions and recommendations in this manual pertaining to outside combustion air. **Outside air for combustion is optional in residential type installations unless required by local codes; it is mandatory in manufactured home installations. Use an AK6 outside combustion air kit in manufactured home installations, instead of the AK4 offered for residential type installations.**

Glass doors (model GD36B or GD36PB by Monessen Hearth Systems) may be installed to receive the maximum benefit from your fireplace. For large fires, the maximum heating benefit from the fireplace will be obtained with the doors open due to the high amount of radiant heat being emitted out of the front opening of the fireplace. With a small fire, or before retiring in the evenings, it is best to operate the fireplace with the doors closed to prevent excessive room air from being drawn up the chimney. When the doors are open, the mesh screens should be closed to help keep burning embers from popping out of the firebox.

Glass doors are mandatory on fireplaces installed in manufactured homes.

WARNING: Fireplaces equipped with glass doors should be operated only with the glass doors fully open or fully closed. If doors are left partly open, gas and flame may be drawn out of the fireplace opening, creating risks of both fire and smoke.

The fireplace also is equipped with a flue damper, which must be open when the fireplace is in use. The flue damper control lever is located inside the fireplace. The counterweighted damper is operated by simply pushing up to open or pulling down to close the damper. When the fireplace is not in use, the damper should be closed to prevent cold air from entering the chimney as well as preventing warm air in the room from escaping up the chimney. NOTE: It is normal for a small amount of smoke to be released from the upper portion of the fireplace the first few times you use your new Monessen Hearth Systems fireplace. This results from an oil residue on the metal. Open a door or window to allow the smoke to escape.

The grate included with this fireplace helps to appropriately locate and contain the burning wood. Failure to use this grate may cause overheating of parts of the fireplace and allow large pieces of burning wood to roll forward out of the firebox. If the grate becomes warped or damaged, it must only be replaced by a Monessen Hearth Systems 055119 grate.

All fireplace chimneys are in direct contact with cold air on the exterior of the structure. Consequently, when the fireplace is not in use, cold air can fall down the chimney of the fireplace to cool off the fireplace chase. Therefore, the fireplace chase must be insulated to minimize the risk of cold air infiltration to the home. Even if the fireplace chase is adequately insulated, this cannot completely ensure that cold air infiltration into the structure will be eliminated. Cold air infiltration is a possibility with any fireplace or device that freely communicates with the air on the outside of the structure. Today’s homes are more energy-efficient and, therefore, better insulated and tightly constructed. Unfortunately, when air is removed from the house, as by a bathroom fan, or consumed by a furnace, additional air is needed to replace the air consumed. Unless the additional air is

OPERATION GUIDELINES

supplied, this can cause a negative pressure in the home. When this happens, the house will draw in outside air from the cracks in the windows, down the fireplace flue or other locations of air leakage in the home. Because cold air infiltration may be unavoidable in some structures, Monessen Hearth Systems is not responsible for heat loss or air infiltration through or around the fireplace.

CLEARANCES

FIGURE 1

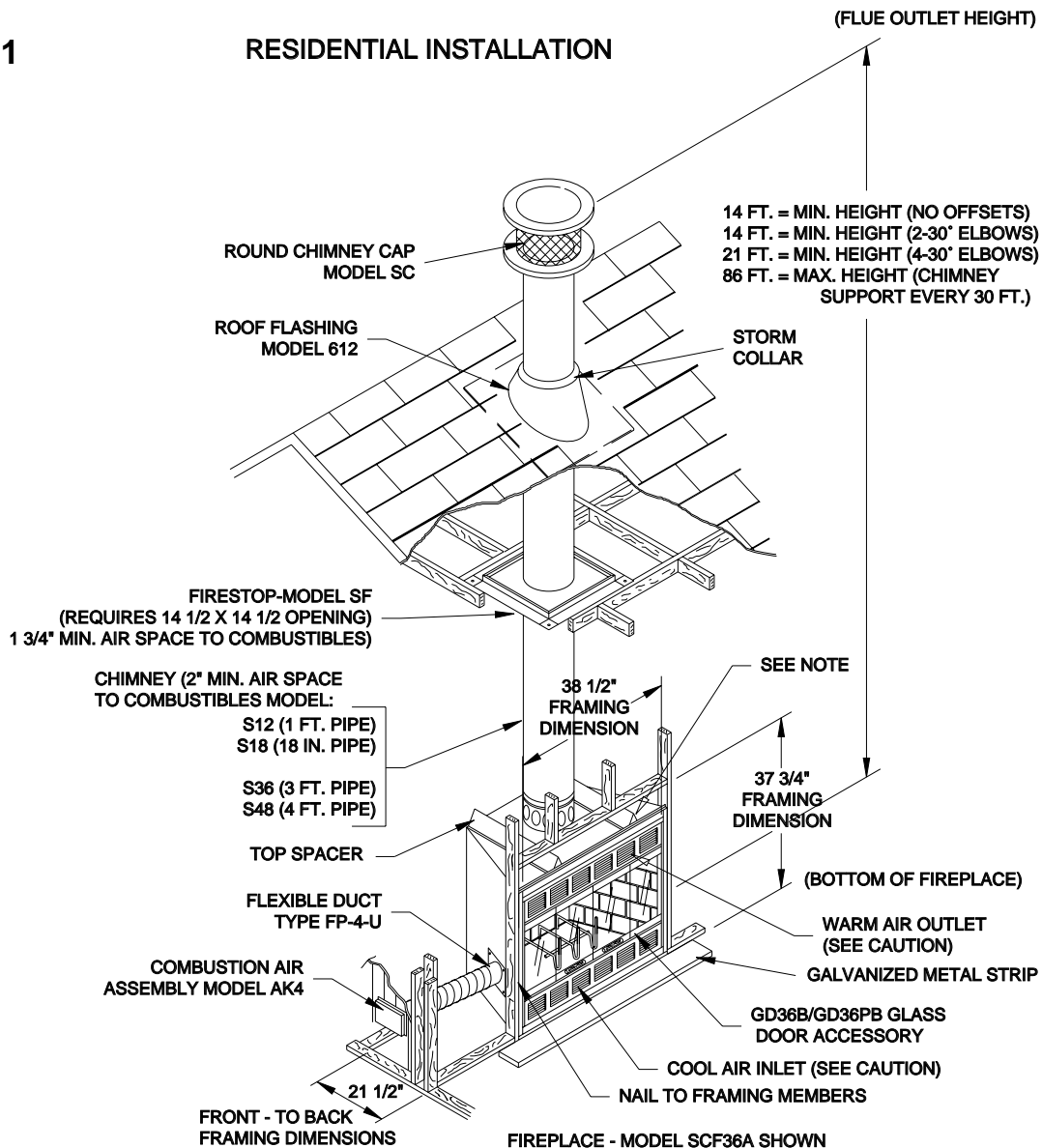

CAUTION: DO NOT BLOCK AIR INLETS OR OUTLETS.

NOTE: COMBUSTIBLE MATERIALS SHOULD NOT BE INSTALLED BELOW TOP SPACER. NON-COMBUSTIBLE MATERIALS SUCH AS BRICK OR TILE MAY BE USED TO TRIM FACE OF THE FIREPLACE BUT SHOULD NOT COVER ANY PORTION OF THE LOUVERED PANEL OR COOL AIR INLET. COMBUSTIBLES MUST NOT OVERLAP THE BLACK PAINTED FACE OF FIREPLACE.

CLEARANCES

FIGURE 2

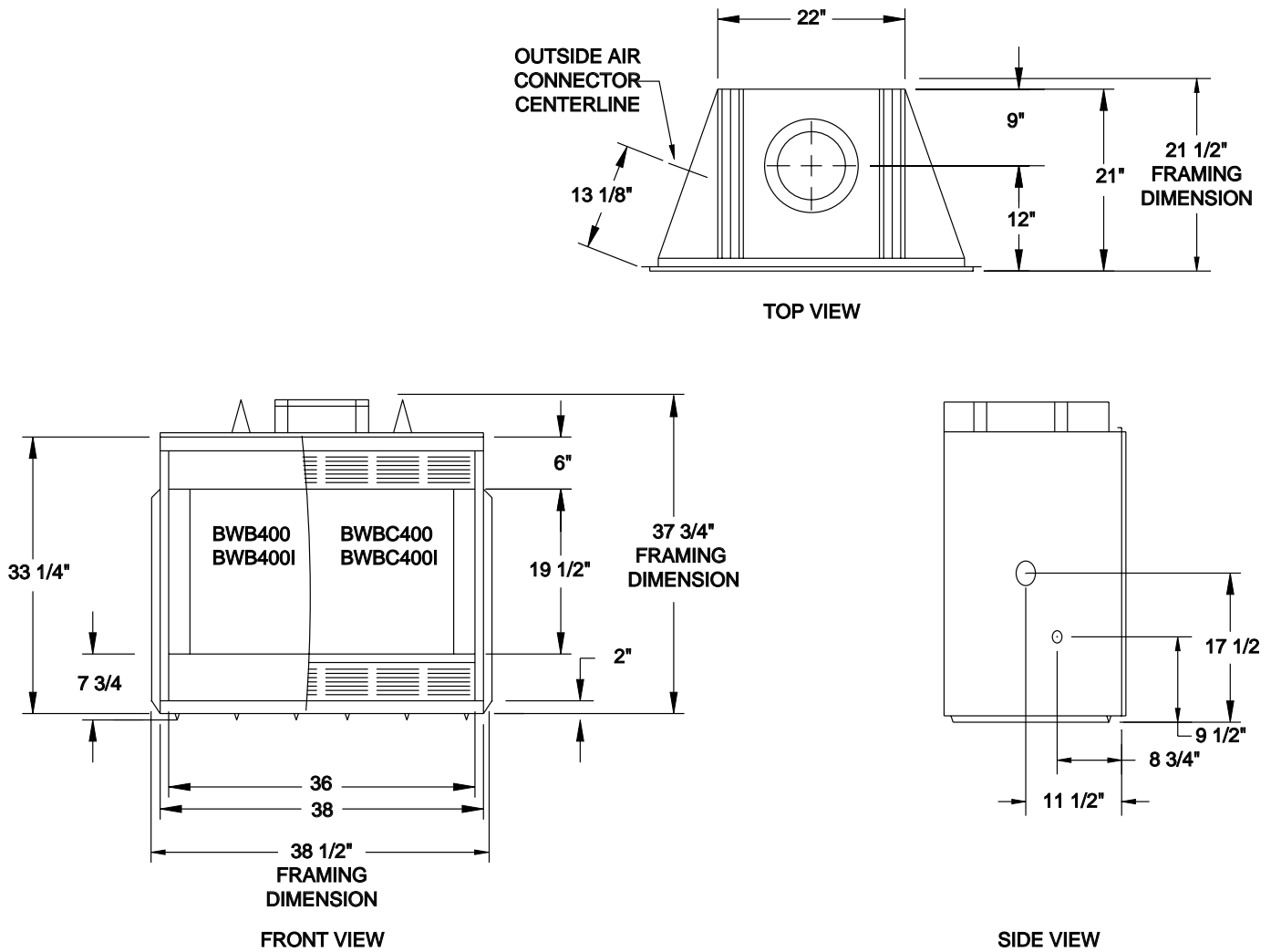
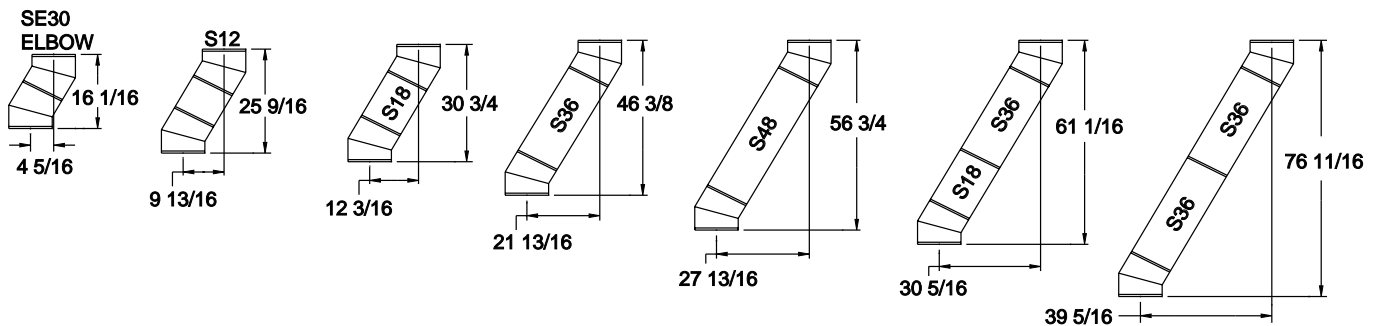

FIGURE 3



NOTE: DIMENSIONS MAY VARY SLIGHTLY DUE TO MANUFACTURING TOLERANCES.

FIREPLACE LOCATION

CAUTION: Do not install fireplace over carpeting.

This fireplace does not weigh more than large pieces of furniture and can normally be located near a load bearing wall without requiring additional foundations or supports. If however, the fireplace is to be trimmed with a heavy stone or brick facing and hearth extension, be sure the supporting structure is adequate.

Figures 4 and 5 provide dimensional details of the fireplace, required spacing to combustibles walls, and some suggested fireplace locations. When selecting a location, choose one that is away from frequently opened doors, central heat outlets or returns, or other places where air movements may disturb the airflow around the fireplace. Air turbulence near the fireplace may cause smoke to spill out of the fireplace opening.

FIGURE 4

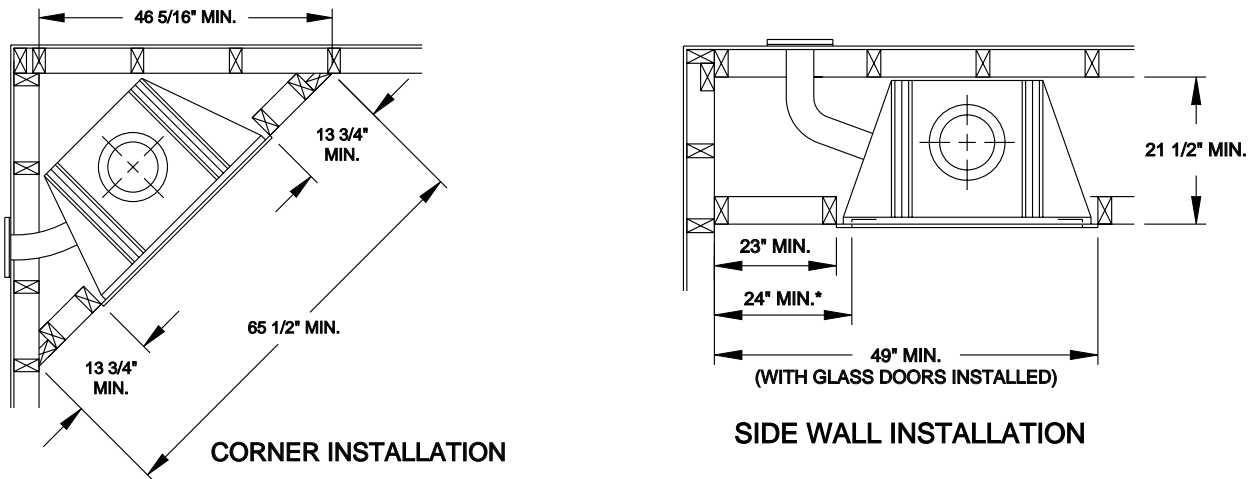
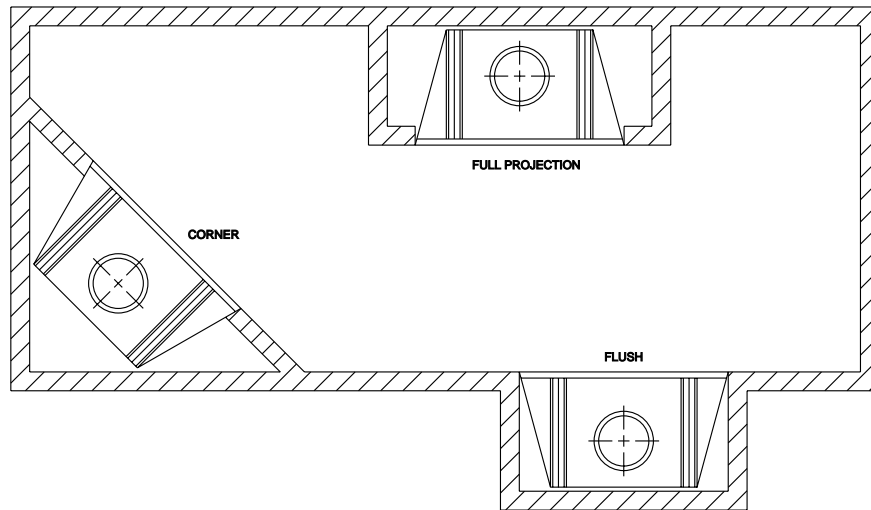

FIGURE 5



INSTALLATION PREPARATION

Survey the planned location for the fireplace for overhead plumbing or electrical wires, etc., that might complicate the installation or endanger persons installing or cleaning the chimney. Avoid a location where the chimney cap will be near abrupt changes in the roof shape, nearby wall or embankments, under or near trees or above the roof of a single story wing of a two story building as shown by Figure 8. All these conditions can cause turbulence or pressure conditions that can cause poor chimney draft and smoke spillage from the fireplace opening. Elbows may be used to offset the chimney to avoid obstructions or to locate the chimney cap in a preferred location. Refer to the sections of this manual pertaining to chimney offsets for instructions on proper elbow use. Poor installation or location of the chimney cap and/or components can cause wind blown rain to enter the chimney.

Be sure the selected location will allow a 14" square combustible material-free space for the chimney to pass through. If the chimney is to pass through living or storage spaces, be sure there is adequate space to enclose the chimney to avoid personal contact with, or damage to, the chimney. If the fireplace is to be installed on an outside wall, the surrounding walls (chase) should be constructed and insulated as shown by Figure 6. Failure to insulate the fireplace from outside temperatures will cause heat loss through and around the fireplace.

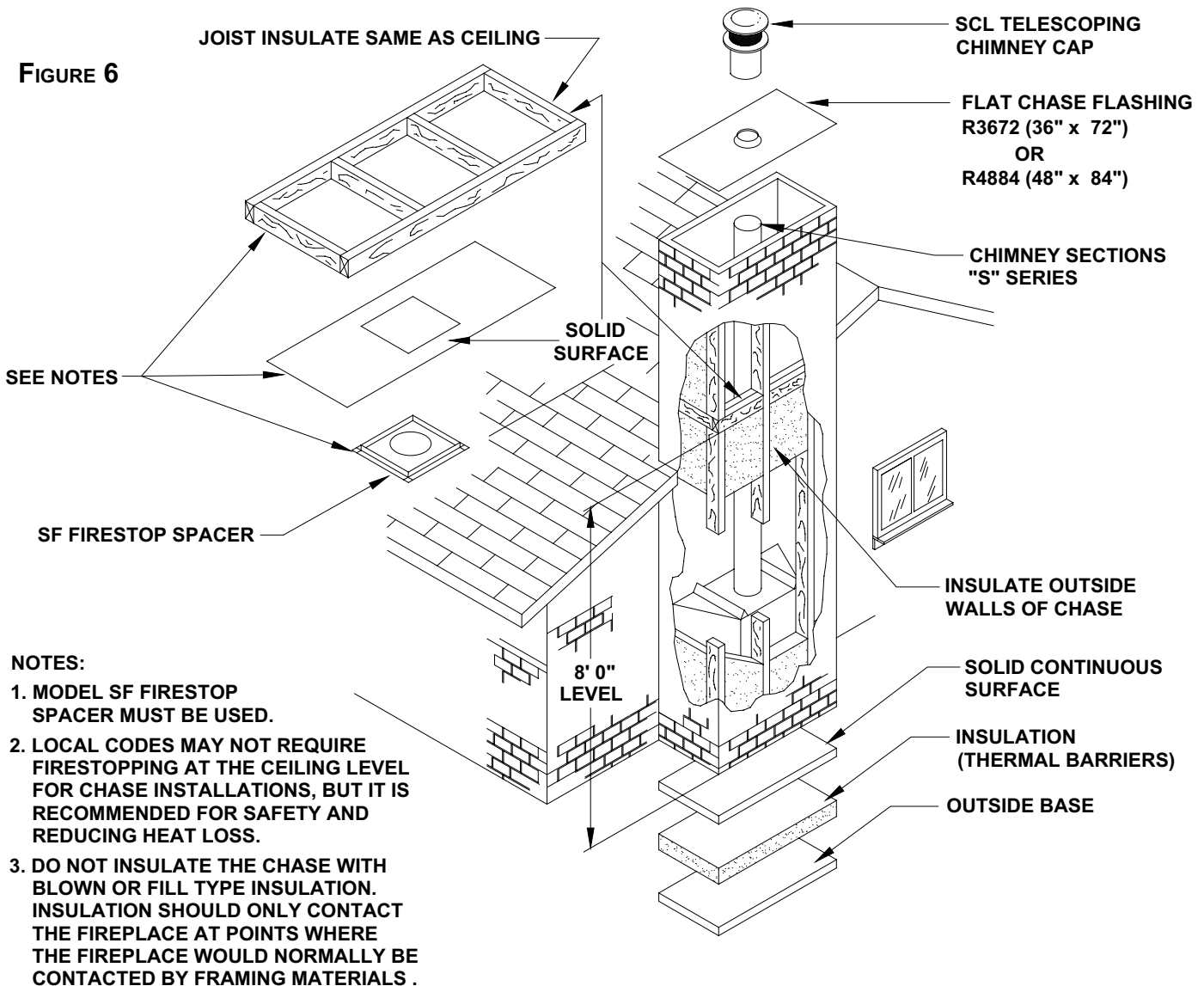

INSTALLATION PREPARATION

FIGURE 7

SINGLE STORY INSTALLATION WITH ATTIC SPACE

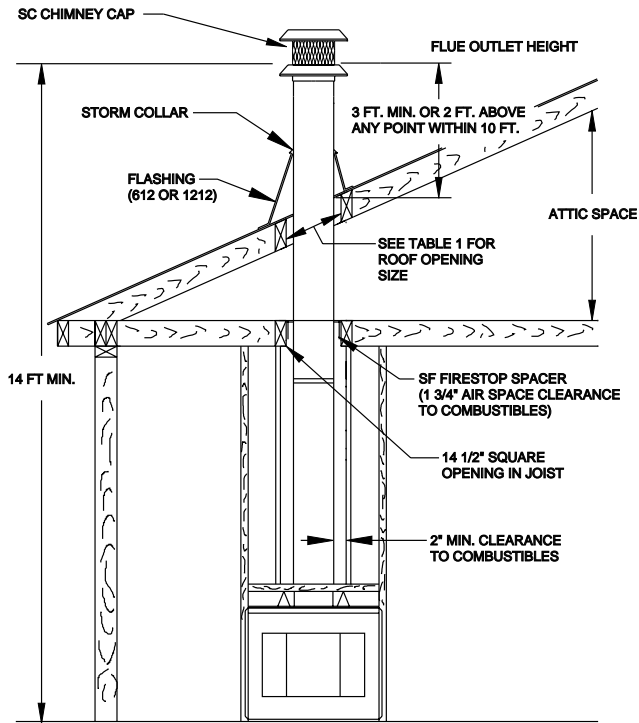

FIGURE 8

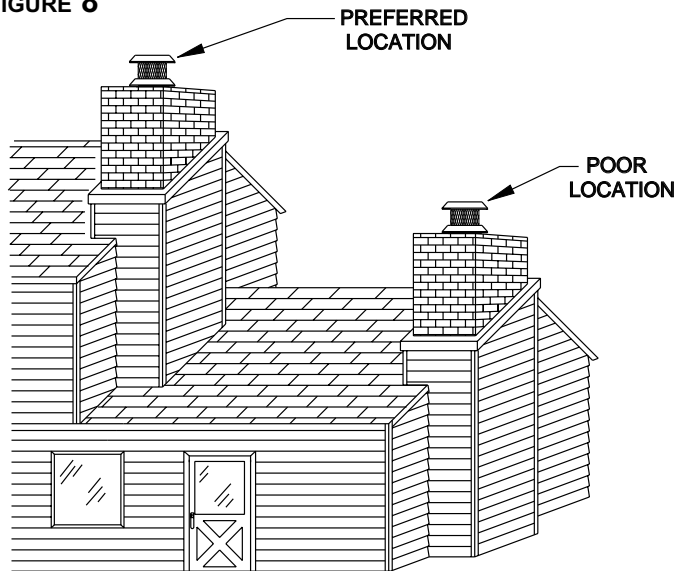
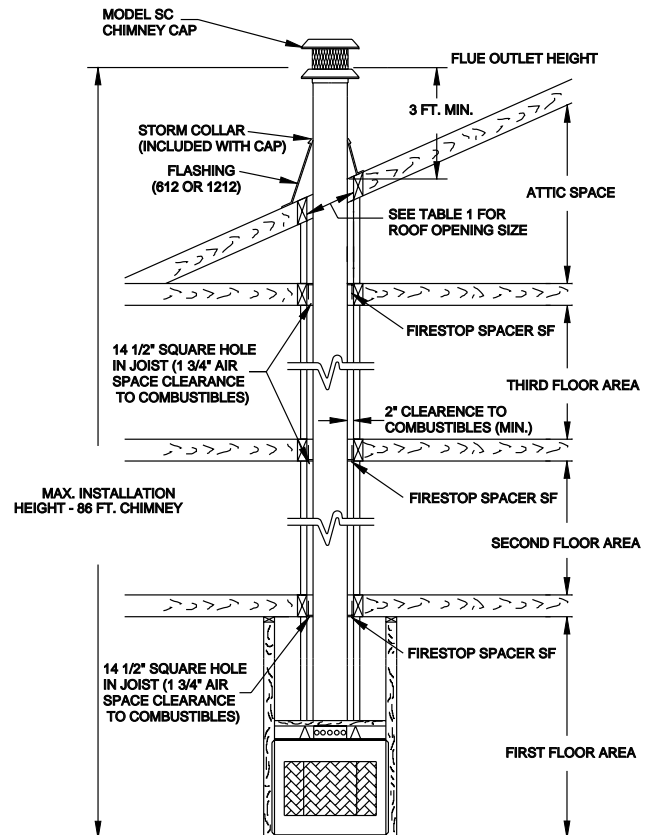

FIGURE 9

MULTIPLE STORY INSTALLATION



FLOOR PROTECTION

If this fireplace is installed on a combustible floor, the floor area 16 inches in front of, and 8 inches either side of the fireplace opening must be protected by an insulating noncombustible hearth extension. This hearth extension may be either minimum 6-inch thick stone or brick as shown by Figure 10, a H1652 Hearth Extension Kit or a locally constructed hearth equivalent which has a "K" factor less than .43.

FIGURE 10

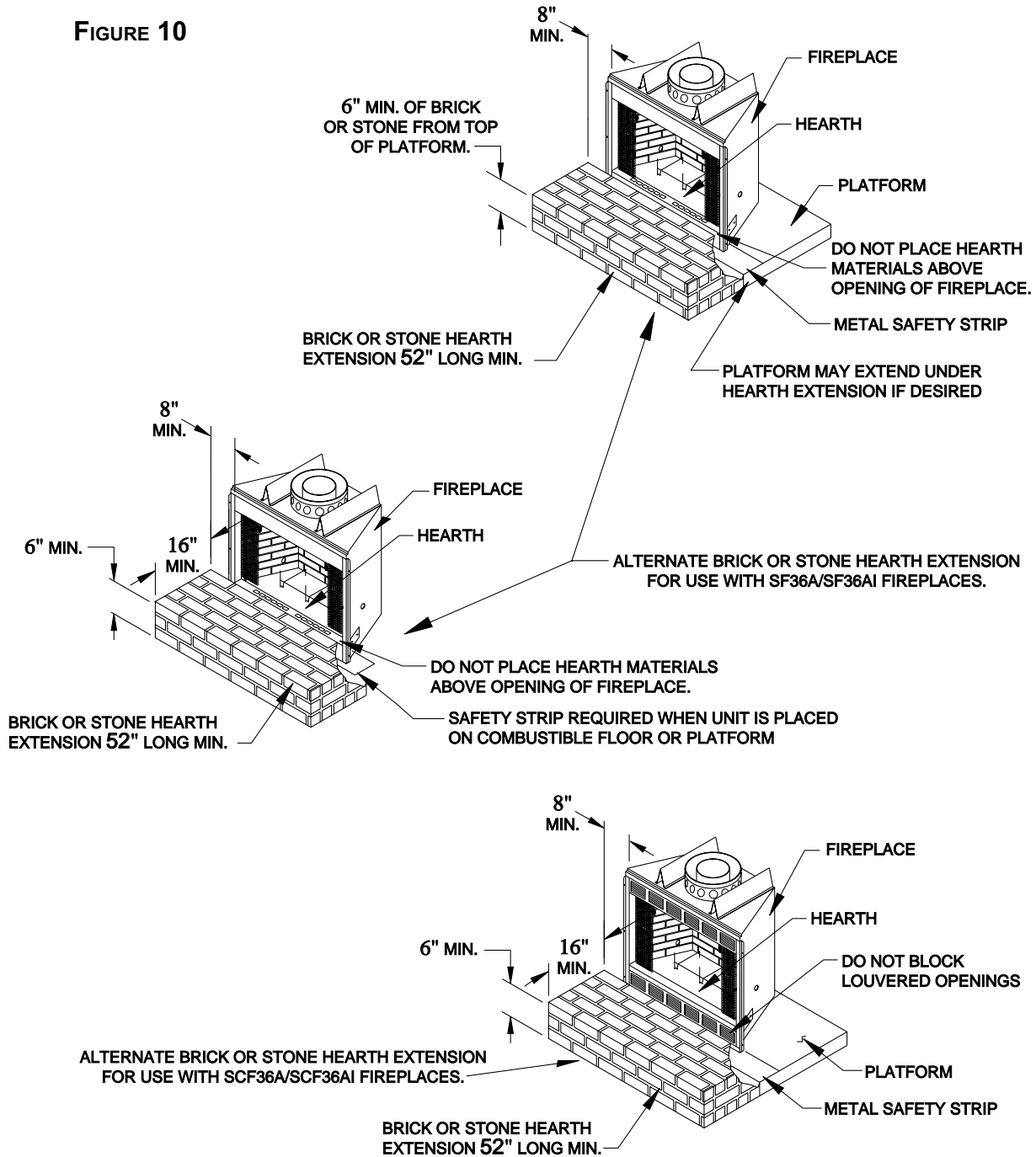

FLOOR PROTECTION

The ability of insulating material to retard the transfer of heat may be expressed as either Thermal Conductance (C), Thermal Conductivity (K), or Thermal Resistance (R). The mathematical relationship of these values and the formulas for converting one value to another is as follows:

$C = K$ divided by the material thickness
 (Example $C = .43$ divided by $1/2 (.50)$
 $C = .86$)

$K = C$ multiplies by the material thickness
 (Example $K = .86$ multiplied by $1/2 (.50)$
 $K = .43$)

$R =$ The material thickness divided by K
 (Example $R = 1/2 (.50)$ divided by $.43$
 $R = 1.16$)

FIGURE 11

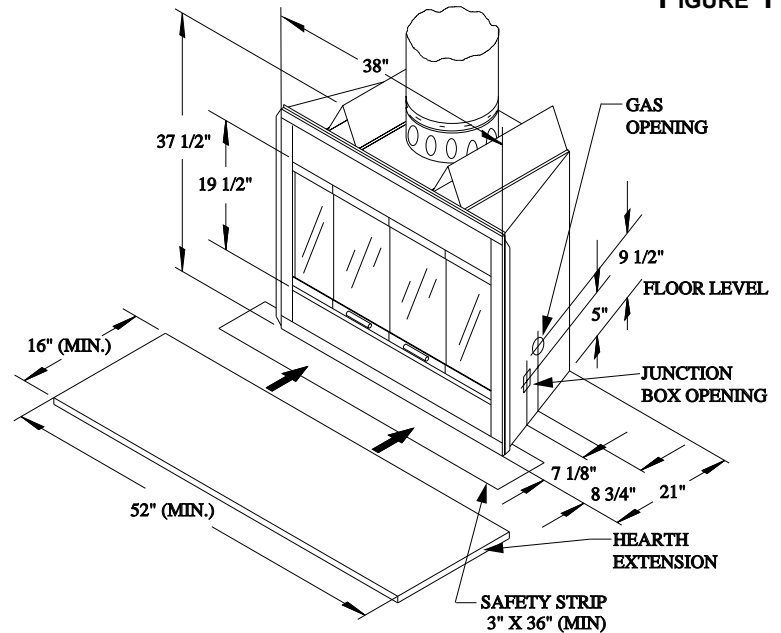
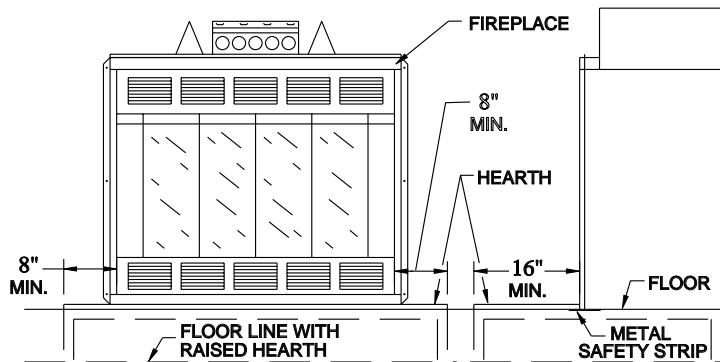

FIGURE 12



WARNING:
 THE HEARTH EXTENSION AND
 THE GALVANIZED METAL STRIP
 SHOULD BE INSTALLED ONLY IN
 A HORIZONTAL RELATIONSHIP TO
 THE FIREPLACE, AS ILLUSTRATED.

With either type hearth extension minor shifting of the supporting floor or expansion and contraction may eventually cause a crack to develop between the hearth extension and the face of the fireplace. To help prevent the crack from developing, the hearth extension materials must be firmly fastened in place. Wall ties should be screwed to the face of the fireplace and imbedded in the mortar joints of brick, stone, or other non-combustible materials. The metal safety strip packed with the fireplace must be placed beneath the fireplace and extended under the hearth extension or into a mortar joint of the hearth extension as shown by Figures 10, 11, and 12. In the event a crack does eventually develop, the metal safety strip will serve as a barrier to prevent sparks or embers from falling from the fireplace onto combustible flooring materials.

The hearth extension must not block the side air vents, or air inlet louvers on the lower front of the fireplace. These openings must be unobstructed to assure an adequate flow of cooling air around the firebox. If the fireplace is equipped with a blower, or may be equipped with one at a later date, the hearth extension must not prevent the removal of the lower louver panel for servicing the blower. Plan adequately by determining the finished height of the hearth extension to be used and elevate the fireplace on a platform, if necessary, to prevent obstructing the air openings or lower louvered panel.

FIREPLACE COMPONENTS

FIGURE 13

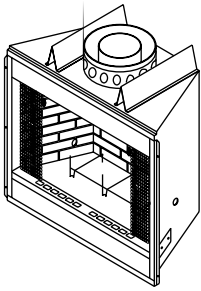

SF36A OR SF36AI
FIREPLACE

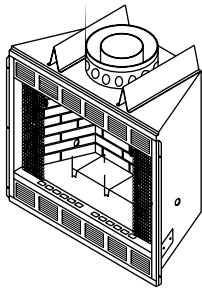

SCF36A OR SCF36AI
FIREPLACE

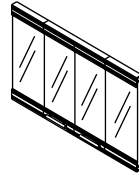

GD36B OR GD36PB
GLASS DOOR KIT

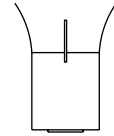

SCS
CHIMNEY
SUPPORT

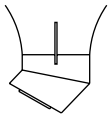

SE30 30°
ELBOW

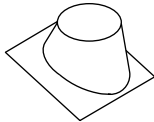

612 OR 1212
FLASHING

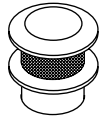

SC ROUND
CHIMNEY CAP

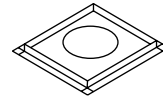

SF FIRESTOP
SPACER

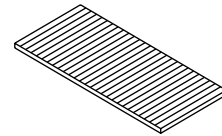

H1652 HEARTH
EXTENSION

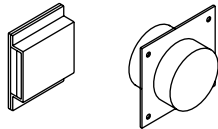

AK4 OR AK6
COMBUSTION
AIR KIT

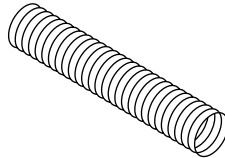

FP4U OR FP6U
UNINSULATED
FLEX PIPE

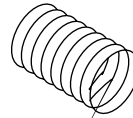

403 OR 603 DUCT
CONNECTOR

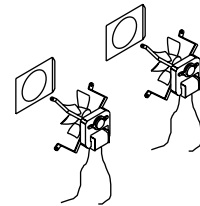

FA2 FAN KIT

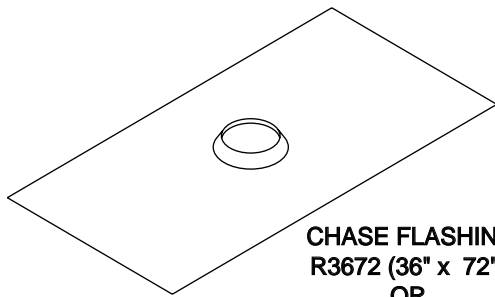

CHASE FLASHING
R3672 (36" x 72")
OR
R4884 (48" x 84")

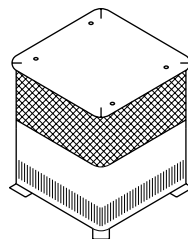

CF8 CHIMNEY CAP

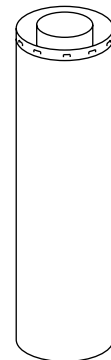

S48, S36, S18, AND S12
CHIMNEY FLUE SECTIONS

FIREPLACE COMPONENTS

SEE FIGURE 13 FOR ILLUSTRATION OF FIREPLACE COMPONENTS DESCRIBED BELOW.

MODEL	DESCRIPTION
SF36A	36-inch radiant fireplace.
SF36AI	36-inch insulated radiant fireplace.
SCF36A	36-inch circulating fireplace.
SCF36AI	36-inch insulated circulating fireplace.
GD36PB	Optional 36-inch polished brass bifold glass door kit. Frame has polished brass finish; tempered glass is clear.
GD36B	Optional 36-inch black bifold glass door kit. Frame has black finish; tempered glass is clear.
SCS	Chimney support. (Required when chimney height exceeds 30 feet.)
SE30	Elbow offset/return package containing two 8-inch diameter 30-degree elbows.
612	0 to 6/12 variable pitch roof flashing. One 612 flashing required with SC round chimney cap on 0 to 6/12 pitch roof.
1212	6/12 to 12/12 variable pitch roof flashing. One 1212 flashing required with SC round chimney cap on 6/12 to 12/12 pitch roof.
SC	Round chimney cap for contemporary installation; includes storm collar.
SF	14-1/2" firestop spacer. One required at each ceiling or floor level.
★ SCL	Round chimney cap with telescoping pipe and storm collar. For chase installation.
★ SQ8	Square termination chimney cap (18-1/2" x 18-1/2") for chase installation. Use with VFK flashing kit.
★ SF30	Firestop spacer for 30-degree chimney incline through ceiling or floor.
H1652	16-inch x 52-inch hearth extension for protecting floor against sparks and radiant heat.
AK4	4-inch diameter outside combustion air kit. Allows air from outside to enter fireplace. (For residential homes.)
AK6	6-inch diameter outside combustion air kit. Allows air from outside to enter fireplace. (For manufactured homes.)
FP4U	4-inch diameter x 8-foot long flexible uninsulated combustion air duct. Use with AK4 kit.
FP6U	6-inch diameter x 8-foot long flexible uninsulated combustion air duct. Use with AK6 kit.
403	4-inch duct connector for splicing FP4U ducts. (Includes one connector and two clamps.)
603	6-inch duct connector for splicing FP6U ducts. (Includes one connector and two clamps.)
FA2	Optional fan kit, with switch. The FA2 fan installs behind the lower grille of the SCF36A and SCF36AI fireplaces. (For SCF36A and SCF36AI fireplaces.)
★ JB1	Junction box - For Optional FA2 Fan installation on SCF36A and SCF36AI fireplaces. The JB1 junction box must be installed at the time of fireplace installation if the FA2 Fan is to be installed at any time.
★ S8	8-inch diameter double-wall telescope pipe for use with LFSQT chimney cap.
★ LFSQT	Square shroud termination chimney cap for chase installation. Use with S8 telescope pipe and VFK flashing kit. (Minimum chase top dimensions: 26" x 26".)
★ SPC	Pyramid shroud termination chimney cap for chase installation.
★ H36	Hood for heat deflection. Hood may be installed on fireplace in residential type home to reduce the recommended clearance to a combustible mantle. This hood is not for use with glass doors.
R3672	36" x 72" flat chase flashing with single flue hole.
R4884	48" x 84" flat chase flashing with single flue hole.
CF8	Terra Cotta masonry-look termination chimney cap for chase installation. Use with VFK flashing kit.
★ VFK	Vent flashing kit consisting of adjustable radiation shield with spacer brackets and fasteners. (For venting a field-constructed flashing assembly on a combustible chase top.)
S48	48-inch long x 8-inch diameter chimney flue section.
S36	36-inch long x 8-inch diameter chimney flue section.
S18	18-inch long x 8-inch diameter chimney flue section.
S12	12-inch long x 8-inch diameter chimney flue section.

★ : DENOTES FIREPLACE COMPONENTS NOT ILLUSTRATED BY CORRESPONDING FIGURE.

FIREPLACE INSTALLATION

LOCATION SELECTION

Unpack and check the fireplace and chimney for damage. If any items have been damaged, report this to your Monessen Hearth Systems dealer. Before beginning the installation, be sure you have the proper parts in sufficient quantity. Refer to the Parts Diagram and List section of this manual for proper identification of parts.

Do not substitute parts. Use only parts listed for use with Monessen Hearth Systems Models BWB400, BWB400I, BWBC400, and BWBC400I fireplaces.

FIREPLACE INSTALLATION

1. Refer to Figure 1 for an example of a typical installation of the fireplace components.
2. Be sure the location of the fireplace will provide the required clearances indicated by Figures 1, 2, 4, & 5 and the minimum chimney air space clearance to combustibles of two inches.
3. Set the fireplace in the desired location and be sure it is securely supported and leveled. Check the face of the fireplace with a carpenter's level and if it is not plumb; correct it by placing shims under the edges of the fireplace.
4. Block in the fireplace to prevent any shifting of the firebox. Secure the fireplace with nails or screws through the flanges located on each side of the fireplace. Do not enclose the fireplace until the combustion air duct and chimney pipes are installed.

NOTE: Some local codes may require electrically grounding the fireplace and chimney.

CHIMNEY INSTALLATION

In order to assure safe and satisfactory performance of the fireplace, it is very important to properly install the chimney. This is an important part of the installation and the sections of this manual pertaining to chimney installation should be reviewed very thoroughly.

For your safety, some of the important things to remember in regard to chimneys are listed below:

1. Use only parts and accessories labeled for use with this fireplace.
2. Use only undamaged parts and accessories.
3. Enclose the chimney where it passes through the living spaces to prevent contact with and possible damage to the chimney.
4. Install firestop spacers at each ceiling level.
5. Install the proper chimney cap or chimney housing on the chimney to prevent the entry of rain and debris into the chimney and to assure the proper venting of smoke.
6. Do not use more than four elbows in the chimney.

NOTE: To select the proper chimney height, refer to Figures 1, 7, 9, and 14. The flue outlet must be a minimum of three feet above the highest point where the chimney penetrates the roof and a minimum of two feet above all portions of the building within ten feet. If the chimney is to include elbows to offset the chimney, refer to the Chimney Offset and Cap Installation section of this manual. There must be at least two inches air space between all sections of the chimney and combustible materials between floors.

CHIMNEY INSTALLATION

FIGURE 14

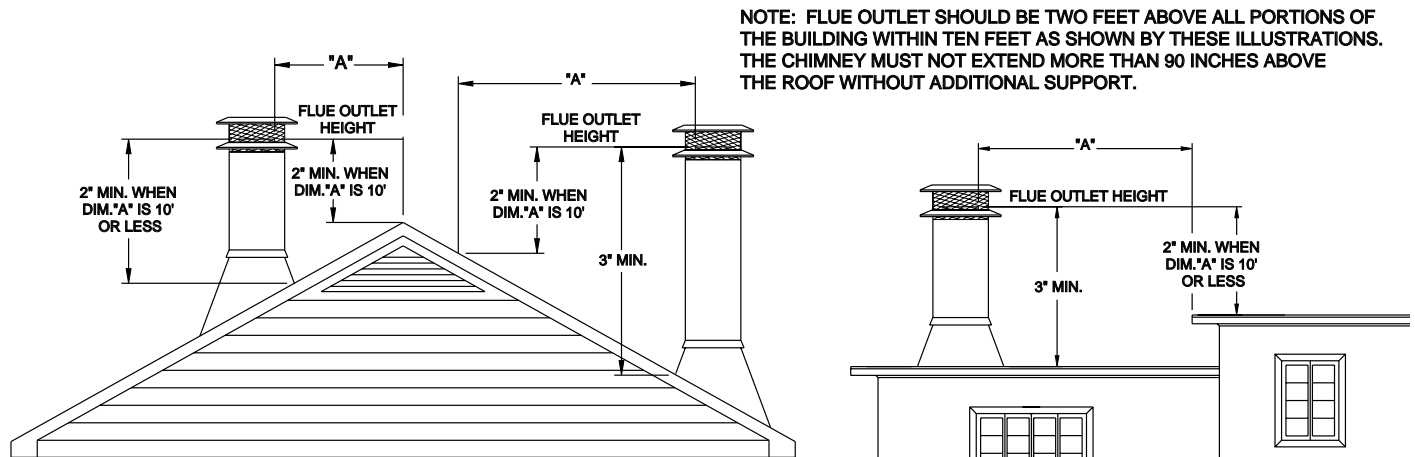

1. Lay out, cut and frame openings through all ceilings and the roof at the point where the chimney will pass through. Unless the chimney is to be offset, the point where the center line of the chimney will pass through the ceiling and roof can be determined with a plumb line as shown by Figure 15. The fireplace should be located in the planned installation position. After the center line is established and a nail is driven to mark the point, the opening can be cut if you are satisfied with the chimney location relative to ceiling and roof joists and/or any other obstructions. The roof opening center line should be marked by driving a nail through the roof from underneath that will penetrate the roof and can be located from the rooftop. If the chimney is to penetrate a pitched roof, the hole in the roof must be rectangular instead of square and should be sized according to Table 1.
2. Install the firestop spacer as required from beneath the ceiling unless the space above is attic space. In an attic, the firestop spacer should be installed at the floor level of the attic. Figure 17. You must have joists or headers on all four sides of the spacer and use a minimum of four 8-penny nails to secure the spacer.
3. To install the “S” series chimney sections, insert the male end of the flue, the smallest diameter pipe, into the flue outlet of the fireplace and press down until the snap locks engage. Continue the process, adding the chimney sections on top of each other until the chimney is at least six inches above the roof opening on all sides. As the chimney sections are installed, check each joint to make sure it is properly locked to the previous section. If additional strength of the outer pipe joints is desired, you may use two or three sheet metal screws placed through the area where the outer pipes overlap one another. To install these screws, drill a 1/8-inch diameter hole through the chimney sections, taking care not to penetrate the inner flue pipe. Warning: Be very careful when drilling the holes into the outer pipe. The drill must not penetrate the inner stainless steel pipe.

NOTE: If you intend to have a total fireplace installation of more than 30 feet you must use chimney support model SCS at or below 30 feet to support the weight of additional chimney pipe.

To install the chimney support, place the crimped end of the flue and outlet air duct portions into the last section of chimney pipe. Push down until the outside or inlet air duct of the chimney support overlaps and snap locks the chimney support into the chimney section.

Nail the support straps tightly to a building frame member or ceiling joist as shown by Figure 16. You must use at least two 8-penny nails per strap.

CHIMNEY INSTALLATION

FIGURE 15

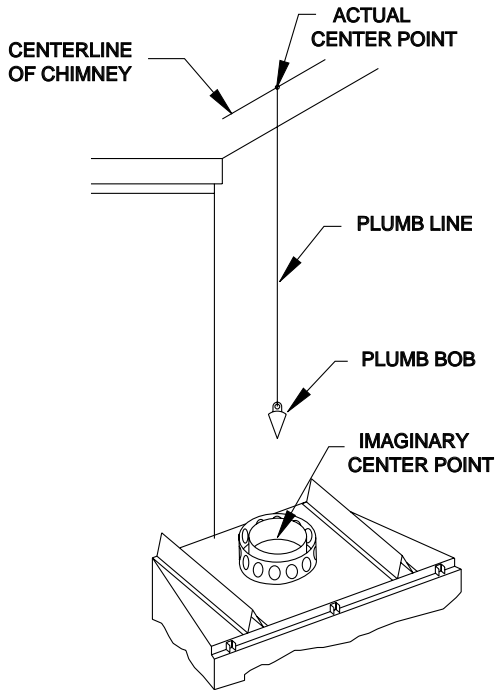
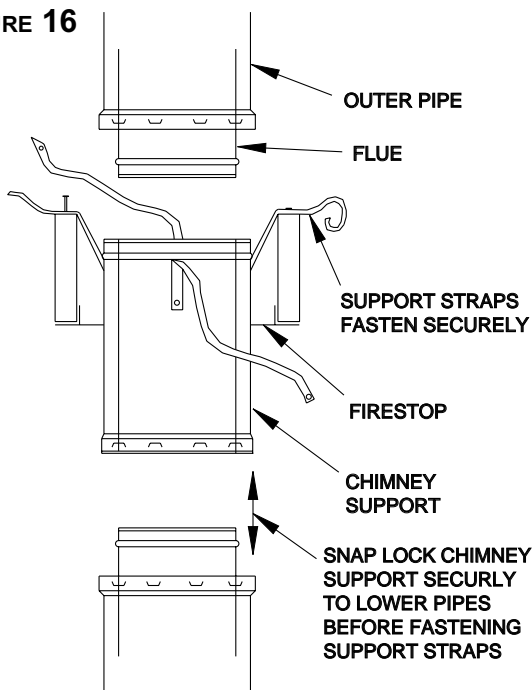

TABLE 1

ROOF PITCH	MINIMUM REQUIRED ROOF OPENING MINIMUM FRAMED OPENING	
	"S" SERIES DOUBLE WALL CHIMNEY	"E" SERIES DOUBLE WALL CHIMNEY
0/12	14 1/2" x 14 1/2"	17" x 17"
1/12	14 1/2" x 14 5/8"	17" x 17" 1/8"
2/12	14 1/2" x 14 3/4"	17" x 17" 1/4"
3/12	14 1/2" x 15"	17" x 17" 1/2"
4/12	14 1/2" x 15 1/4"	17" x 17" 3/4"
5/12	14 1/2" x 15 3/4"	17" x 18" 1/4"
6/12	14 1/2" x 16 1/4"	17" x 18" 3/4"
7/12	14 1/2" x 16 7/8"	17" x 19" 3/8"
8/12	14 1/2" x 17 1/2"	17" x 20"
9/12	14 1/2" x 18 1/8"	17" x 20" 5/8"
10/12	14 1/2" x 18 7/8"	17" x 21" 3/8"
11/12	14 1/2" x 19 3/4"	17" x 22" 1/4"
12/12	14 1/2" x 20 1/2"	17" x 23"

FIGURE 16



INSTALLATION OF FIRESTOP-SPACER AT ATTIC LEVEL

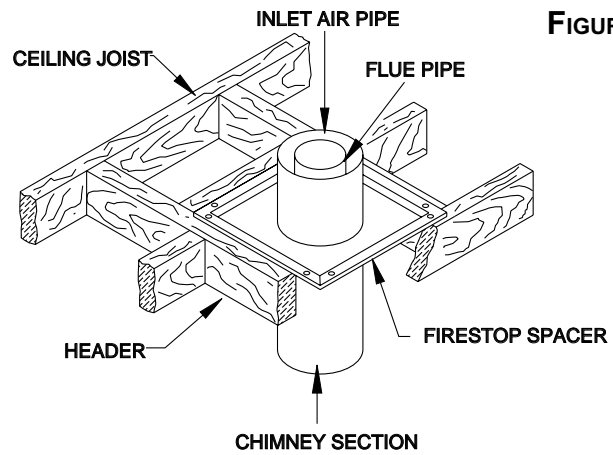
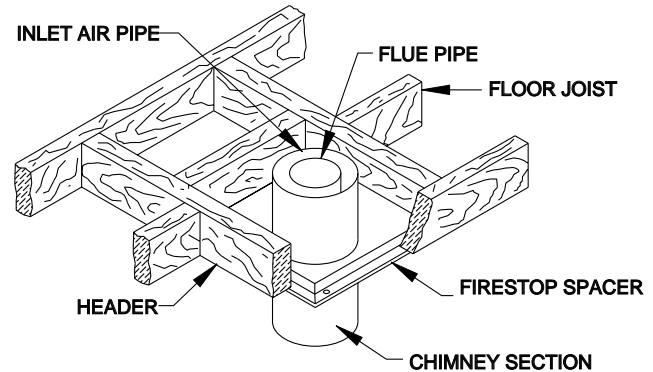

FIGURE 17

INSTALLATION OF FIRESTOP-SPACER AT FLOOR LEVELS



CHIMNEY OFFSET INSTALLATION

ELBOW INSTALLATION

The following are important points that should be observed when installing elbows on the fireplace:

1. The support straps of all elbows not installed directly on top of the fireplace should be nailed securely to the surrounding structure. This allows the support strap to carry the weight of the chimney above the elbow and prevents this weight from breaking the elbow or chimney sections apart. Figure 18.
2. Elbows should not be used in any combination that inclines the chimney more than 30 degrees from vertical.

FIGURE 18

THE SUPPORT STRAPS OF ALL ELBOWS NOT INSTALLED DIRECTLY ON TOP OF THE FIREPLACE SHOULD BE NAILED SECURELY TO THE SURROUNDING STRUCTURE.

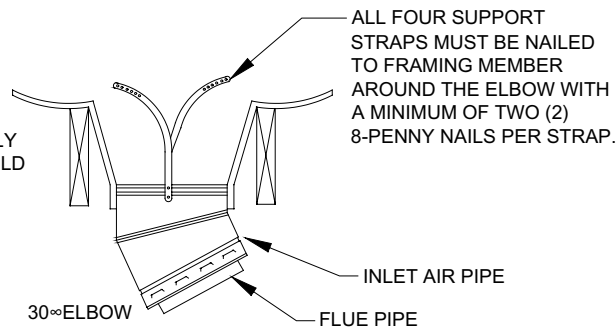

3. The limitations on the quantity of elbows per chimney are as follows: If the total height of the fireplace and chimney is — 13' 6" or more — two elbows may be used in the chimney. 21' 0" or more — four elbows may be used in the chimney.
4. The inclined portions of chimneys that pass through living spaces likely to be used for storage should be enclosed to avoid contact with and possible damage to the chimney. The minimum air space of two inches between the chimney and enclosing materials must be maintained. Figures 20 and 21 illustrates elbow installations.
5. The length of the inclined portion of chimney between elbows must not exceed 6 feet when unsupported or 20 feet if the chimney is supported at six-foot intervals with support such as metal support straps.
6. When enclosing the elbows and inclined portions of the chimney, enclosing materials must be installed vertically to maintain the required two-inch minimum air space clearance to the chimney at the extremities of the offset. It is recommended that enclosing material not follow the inclined portions of the chimney.

OFFSET INSTALLATION SEQUENCE

1. Determine the location and amount of offset required, then select the combinations of chimney sections and elbows required from the offset chart. Refer to Table 2.
2. Install the first SE30 elbow by placing the extended flue into the mating part of the fireplace or chimney section. Push down until the outside or inlet air duct of the elbow overlaps and the snaps lock the elbow into the fireplace or chimney section.
3. Nail the support straps to the framing member with a minimum of two 8-penny nails per strap.
4. Install the sections of pipe between elbows until the proper number of chimney sections have been installed.
5. Install the second elbow to return the run of the chimney to vertical.
6. Nail the support straps of the second elbow to a building frame member.
7. Continue installing the vertical portion of the chimney.

NOTE: If the inclined portion of the chimney passes through a floor or ceiling, an SF30 firestop spacer should be installed to provide the firestop and support required. Be sure proper spacing is maintained between the chimney and combustibles. Figure 19.

CHIMNEY OFFSET AND CAP INSTALLATION

FIGURE 19

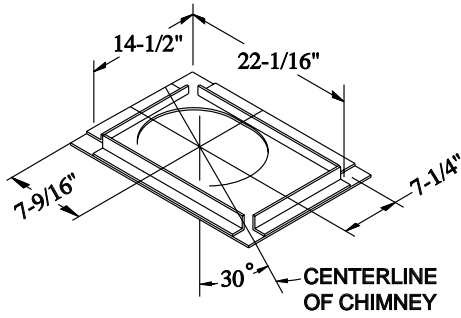

SF30 FIRESTOP SPACER

FIGURE 20

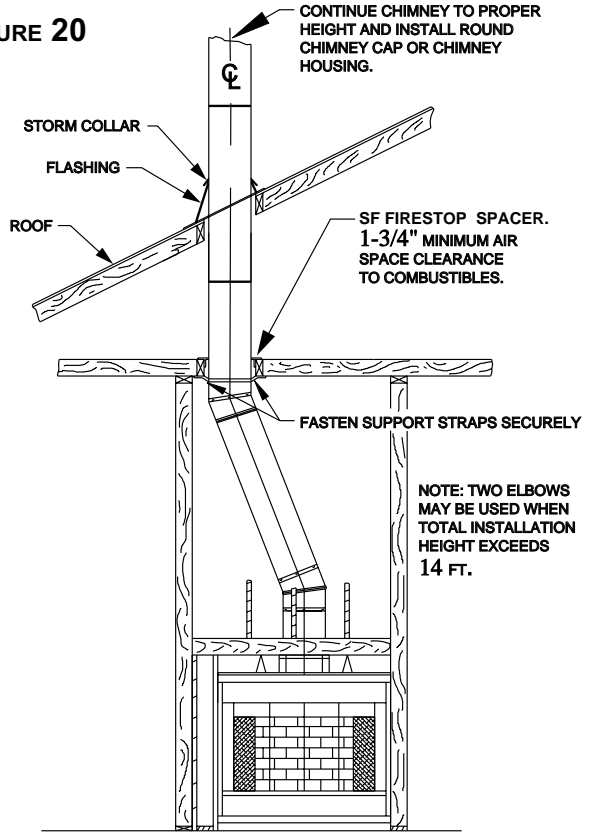

FIGURE 21

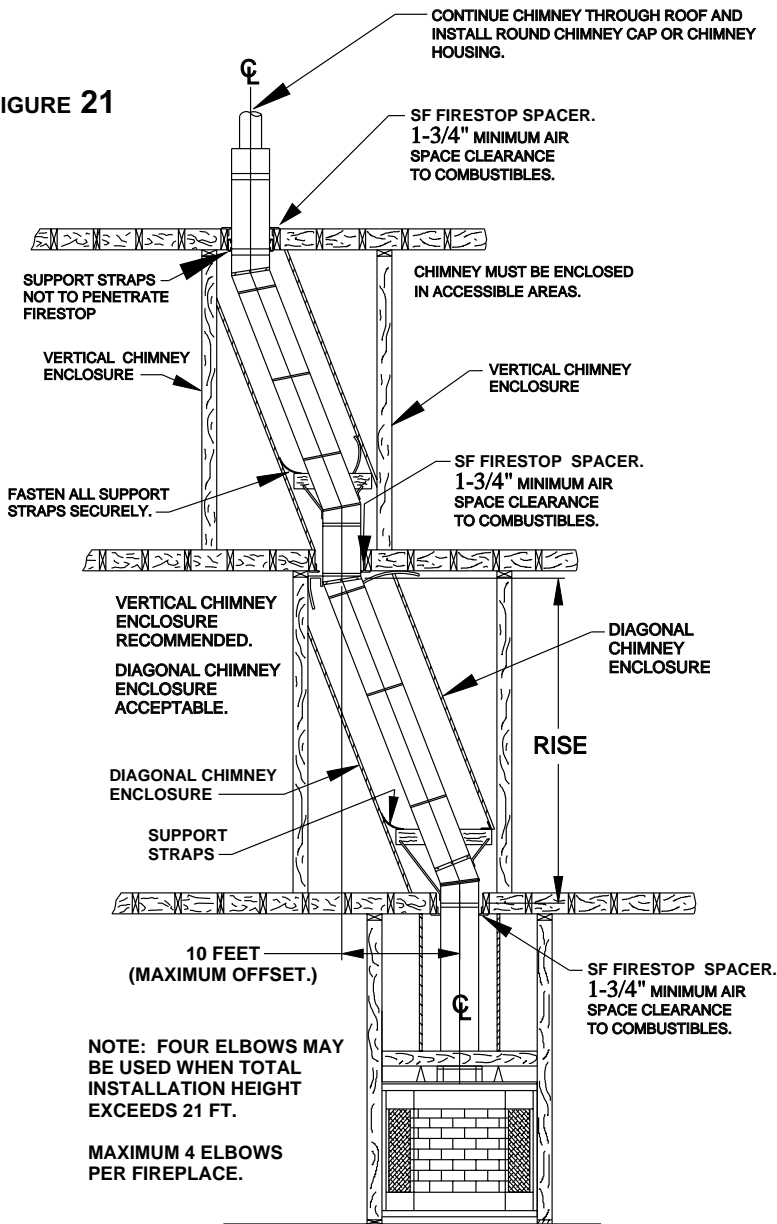
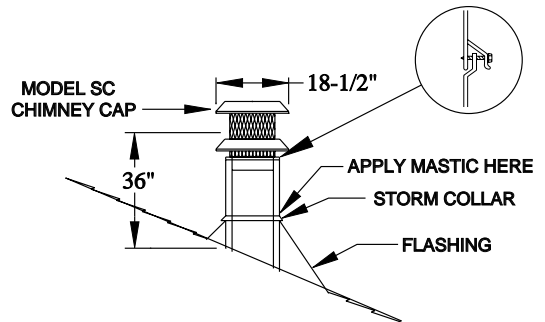
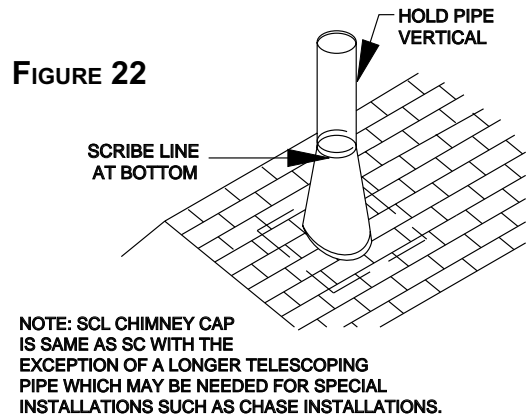

FIGURE 22



CHIMNEY CAP INSTALLATION

MODEL SC CHIMNEY CAP

SPECIAL NOTE: The proper height as previously explained is important to assure proper draft and safety. The chimney cap extends the flue outlet four inches above the top of the last section of chimney. This should be kept in mind when determining the proper height for the chimney. The chimney should not be extended more than 90 inches above the supporting roof structure without additional support. In the case of an "A" frame type construction or other steep pitch roofs that require more than 90 inches of chimney above the roof, a support should be attached to the chimney at the 90 inch level that is strong enough to support a wind load of 3-1/8 pounds for each inch the chimney extends above 90 inches. The flue outlet must be a minimum of three feet above the point where it penetrates the roof. Figure 14.

CAUTION: Be careful to avoid electrical shock hazard when contacting wires to the metal chimney components.

1. Extend the regular chimney sections until the top of the chimney is 4 inches below the total flue height desired. Do not snap the last section of inlet air duct or largest diameter pipe in place until Step 3 is completed.
2. Remove the shingles from around the chimney so that the flashing may be installed, with the upper part of the flashing under the shingles.
3. Set the flashing on the roof and scribe a line around the flashing, then cut the top off the flashing by cutting 1/4 inch below the scribed line. This should increase the diameter of the flashing outlet sufficiently to allow the flashing to be placed over the chimney. See Figure 22.
4. Snap the last section of inlet air duct in place and slide the flashing over the chimney. Adjust the chimney to assure that the proper minimum clearances are maintained.
5. Nail the flashing securely in place with eight nails.
6. Seal the crack between the top of the flashing and the chimney with mastic. Leave some excess mastic at this area to be used in step eight. **NOTE:** Use pliers and wear gloves when performing step seven to minimize the danger of cutting your hands on the edge of the storm collar.
7. Place the storm collar around the chimney and put the collar together like a belt in belt loops. Slide the end of collar under the two loops on the other end with the loops facing up. Overlap the ends of the collar until it is tight against the chimney. Bend the free end of the collar back over the loops to hold the storm collar securely together. The excess end of the storm collar may be trimmed off.
8. Slide the storm collar down snugly against the flashing until the excess mastic left in step six is forced up into the crack between the storm collar and the chimney. This should make the joint between the flashing and the chimney watertight.
9. Install the chimney cap by placing the cap into matching parts of the last chimney section. Push down until the brackets on the bottom of the chimney cap sits on the chimney pipe. Then punch or drill 1/8 inch diameter holes in the inlet air duct (chimney pipe) where specified on the brackets and fasten it down with the No. 8 screws provided. Do not penetrate the inner stainless steel pipe while installing the screws.
10. Check all the parts of the fireplace, chimney and chimney termination cap to assure that no parts have been damaged or bent during installation and that all parts have been installed properly.

NOTE: The metal used for the chimney cap has a rust protective coating but the cut edges of the parts are not protected. To prevent rusting and rust staining of nearby structures, exposed parts of the chimney and chimney cap should be detergent washed and painted with a galvanized primer paint.

CHIMNEY HEIGHT AND OFFSET CHARTS

TABLE 2

HEIGHT (INCHES)	INTERMEDIATE SECTIONS			
	12"	18"	36"	48"
35	0	0	1	0
39	2	1	0	0
47	0	0	0	1
52	0	1	1	0
58	1	0	0	1
64	0	1	0	1
70	0	0	2	0
75	1	1	0	1
82	0	0	1	1
87	0	1	2	0
94	0	0	0	2
99	0	1	1	1
105	0	0	3	0
111	0	1	0	2
117	0	0	2	1
122	0	1	3	0
129	0	0	1	2
134	0	1	2	1
141	0	0	0	3
146	0	1	1	2
152	0	0	3	1
158	0	1	0	3
164	0	0	2	2
169	0	1	3	1
176	0	0	1	3
181	0	1	2	2
188	0	0	0	4
193	0	1	1	3
199	0	0	3	2
205	0	1	0	4
211	0	0	2	3
216	0	1	3	2
223	0	0	1	4
228	0	1	2	3
235	0	0	0	5
240	0	1	1	4
246	0	0	3	3
252	0	1	0	5
258	0	0	2	4
263	0	1	3	3
270	0	0	1	5
275	0	1	2	4
282	0	0	0	6
287	0	1	1	5
293	0	0	3	4
293	1	0	0	6
305	0	0	2	5
310	0	1	3	4
317	0	0	1	6
322	0	1	2	5
329	0	0	0	7
334	0	1	1	6
340	0	0	3	5
346	0	1	0	7
352	0	0	2	6
357	0	1	3	5
364	0	0	1	7
369	0	1	2	6
376	0	0	0	8

CHIMNEY SECTIONS WITH ELBOW OFFSETS

ELBOW SET	CHIMNEY SECTIONS				TOTAL IN. OFFSET	TOTAL IN. RISE
	12"	18"	36"	48"		
1	0	0	0	0	4 1/2	17
1	1	0	0	0	10	26 1/2
1	0	1	0	0	13	31 3/4
1	2	0	0	0	15 1/2	36
1	1	1	0	0	18 1/2	41 1/4
1	0	0	1	0	22	47 1/4
1	2	1	0	0	24	50 3/4
1	0	0	0	1	28	57 3/4
1	0	1	1	0	30 1/2	62
1	1	0	0	1	33 1/2	67 3/4
1	0	1	0	1	36 1/2	72 1/2
1	0	0	2	0	39 1/2	77 1/2
1	1	1	0	1	42	82
1	0	0	1	1	45 1/2	88
1	0	1	2	0	48	92 1/4
1	0	0	0	2	51 1/2	98 1/2
1	0	1	1	1	54	102 3/4
1	0	0	3	0	57	107 3/4
1	0	1	0	2	60	113 1/4
1	0	0	2	1	63	118 1/4
1	0	1	3	0	65 1/2	122 1/2
1	0	0	1	2	69	128 3/4
1	0	1	2	1	71 1/2	133
1	0	0	0	3	75	139 1/4
1	0	1	1	2	77 1/2	143 1/2
1	0	0	3	1	80 1/2	148 1/2
1	0	1	0	3	83 1/2	154
1	0	0	2	2	86 1/2	159
1	0	1	3	1	89	163 1/4
1	0	0	1	3	92 1/2	169 1/2
1	0	1	2	2	95	173 3/4
1	0	0	0	4	98 1/2	180
1	0	1	1	3	101	184 1/4
1	0	0	3	2	104	189 1/4
1	0	1	0	4	107	194 3/4
1	0	0	2	3	110	199 3/4
1	0	1	3	2	112 1/2	204
1	0	0	1	4	116	210 1/4
1	0	1	2	3	118 1/2	214 1/2
1	0	0	0	5	122	220 3/4

NOTE FOR STRAIGHT RUN CHIMNEYS:

Chimney support required at 25' chimney height.

NOTES FOR CHIMNEYS WITH ELBOW OFFSETS:

The length of the inclined portion of the chimney between elbows must not exceed 6 feet when unsupported, or 20 feet if the chimney is supported at 6 foot intervals using either metal support straps or an LCS chimney support.

The LCS chimney support when installed at a 30 degree angle will add 8" of rise and 4-5/8" of offset to the chimney height calculations.

CHIMNEY CAP CHASE INSTALLATION

The preinstalled chimney sections should be no more than 10 inches below the top of the chase. The installation should be planned so that either a two-foot or three-foot chimney section will be used for the top section. This is necessary to ensure complete engagement of the inlet air telescope and chimney cap into the top section.

CAUTION: Be careful around electrical wires to avoid the electrical shock hazard of contacting the wires with the metal chimney components.

NOTE: When two fireplace chimneys are terminated above the same chase, the centers of the chimney caps should be at least 24 inches apart to help prevent smoke from a fireplace in use from being drawn down the chimney of a fireplace that is not in use. Additional spacing between caps or staggering the height of the caps will further lessen the likelihood of this occurring.

1. Extend the chimney sections until the top of the chimney is not more than 10 inches below the top of the chase.
2. Center the hole in the chase cover over the chimney. The chase cover overhang should be lanced, formed over the chase and secured with nails. This prevents water from seeping under the chase cover. If two or more chase covers are to be used on the same chase, they should be soldered together to form two watertight seams.
3. Place the inlet air telescope inside the hole in the chase cover and lower it down into the mating pipe of the chimney until the flange on the telescope section rest on the flange of the chase cover. Note: All telescoping sections should extend a minimum of three inches inside the mating chimney pipes.
4. Install the SCL or SQL8 chimney cap by placing the cap into the matching duct telescope and flue telescope of the last chimney section as shown by Figure 23. Lower the cap until the brackets on the bottom of the chimney cap rests on the raised flange of the flat flashing, punch or drill 1/8 inch diameter holes in the raised flange of the flat flashing, and fasten the cap to the flashing with the No. 8 screws provided.
5. Check all parts of the chimney and chimney cap to assure that no parts have been damaged or bent during installation and that all parts have been installed properly.

NOTE: The metal used for the chimney and chimney cap has a rust-protective coating but the cut edges of the parts are not protected. To prevent rusting and rust staining of nearby structures, exposed parts of the chimney and chimney cap should be detergent-washed and painted with galvanized primer paint.

FIGURE 23

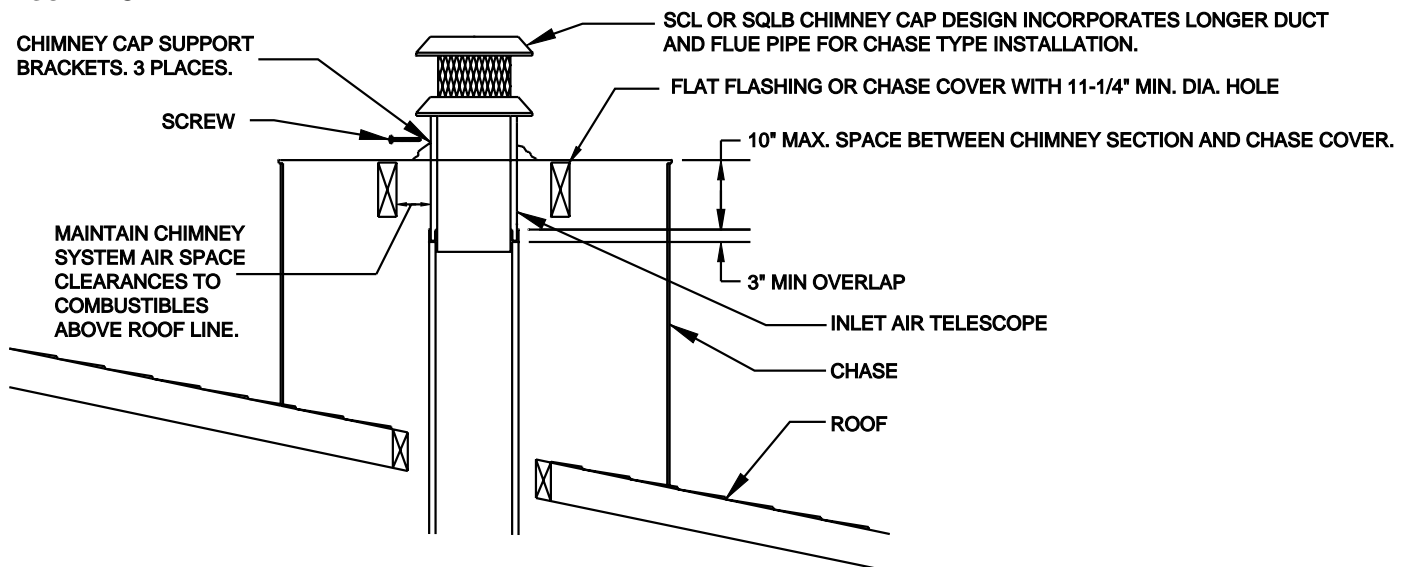

OUTSIDE COMBUSTION AIR PRECAUTIONS AND RECOMMENDATIONS

NOTE: The use of outside air for combustion is optional unless required by building codes. It is only necessary to supply outside combustion air to one side of the fireplace. Use the model AK4 combustion air kit.

FIGURE 24 SECURING OUTSIDE AIR STARTING COLLAR TO FIREPLACE

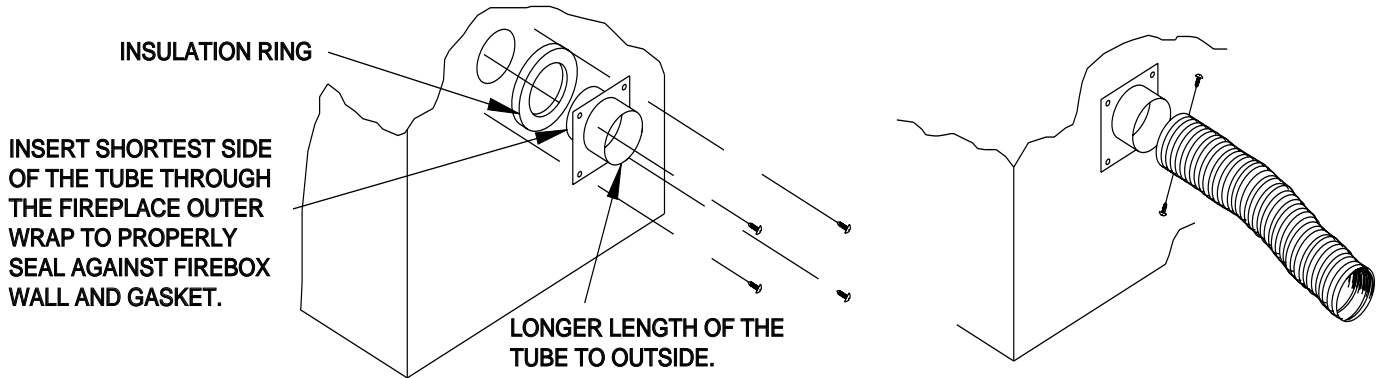

STEP 1: SECURE OUTSIDE AIR STARTING COLLAR TO LEFT SIDE OF FIREPLACE WITH FOUR SHEET METAL SCREWS PROVIDED.

STEP 2: SECURE OUTSIDE DUCT TO STARTING COLLAR WITH DUCT CLAMP ON SCREWS.

NOTE: THE STARTING COLLAR EXTENDS THROUGH THE OUTER FIREPLACE JACKET AND WILL SEAL AGAINST THE FIREBOX WALL WHEN SECURED AS INDICATED.

FIGURE 25

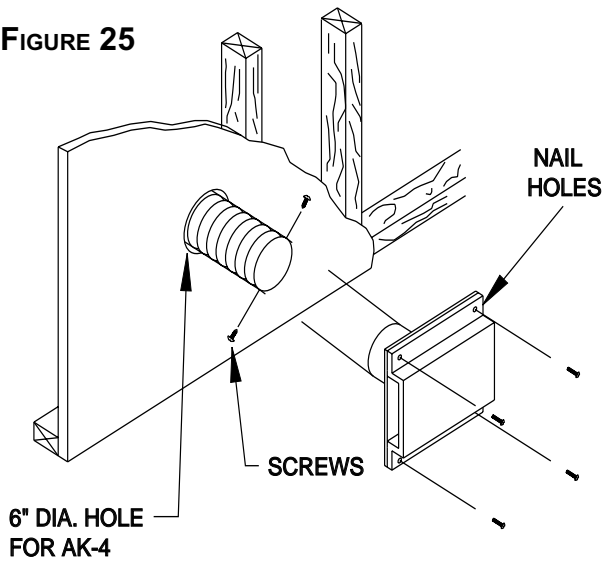

COMBUSTION AIR ASSEMBLY FOR MODEL NO. AK-4

FIGURE 26

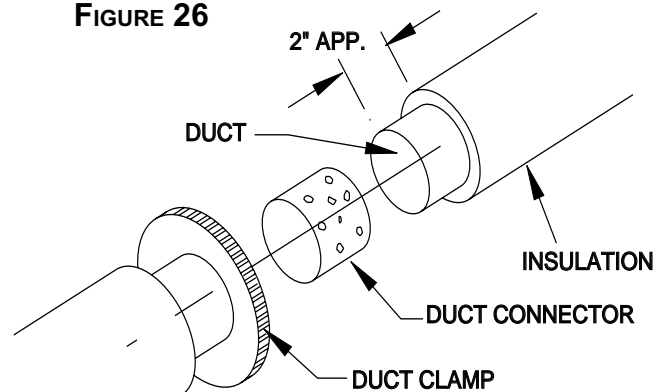

INSTALLATION OF THE MODEL 403 DUCT CONNECTOR

1. Push the insulation back approximately 2" from the end of each duct.
2. Slip each duct over the duct connector until an equal length of the connector extends into each duct.
3. Place a duct clamp over the end of each duct and tighten it down snugly.
4. Push the insulation back into place and over the duct clamp.

OUTSIDE COMBUSTION AIR PRECAUTIONS & RECOMMENDATIONS

OUTSIDE COMBUSTION AIR RECOMMENDATIONS (CONTINUED)

1. Extremely long runs and numerous turns in the duct leading from the fireplace to the combustion air assembly should be avoided. These conditions will increase the resistance to the free flow of air through the duct. Refer to Figures 1 and 27 for methods of installing the outside air for combustion assemblies.
2. The combustion air assembly should be located at an exterior location, which is not likely to be accidentally blocked in any manner. The assembly should be located above the snow line to prevent blockage by snow accumulation.
3. The combustion air inlet assembly should never be mounted in a garage or storage area where combustible fumes such as gasoline might be drawn into the fireplace.
4. Combustion air can be drawn from the crawl space under a house when an adequate supply of air is provided by open ventilation.
5. Do not take combustion air from attic space or garage space.

FIGURE 27

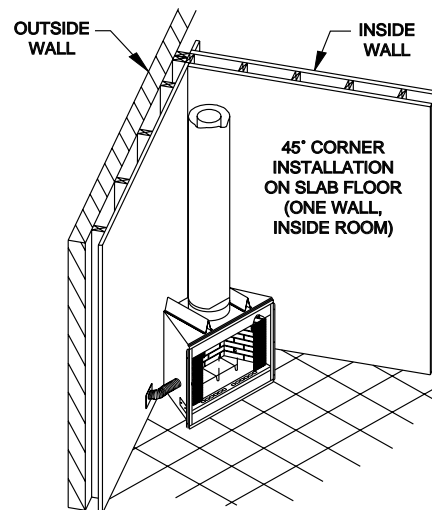
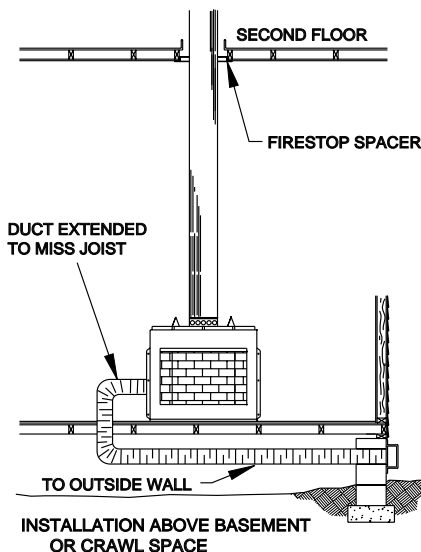
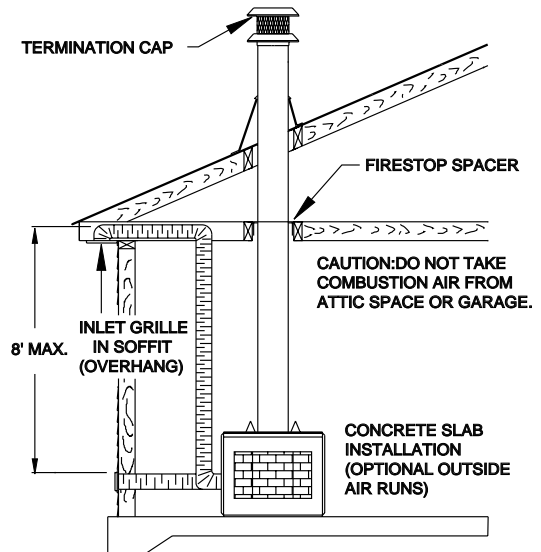
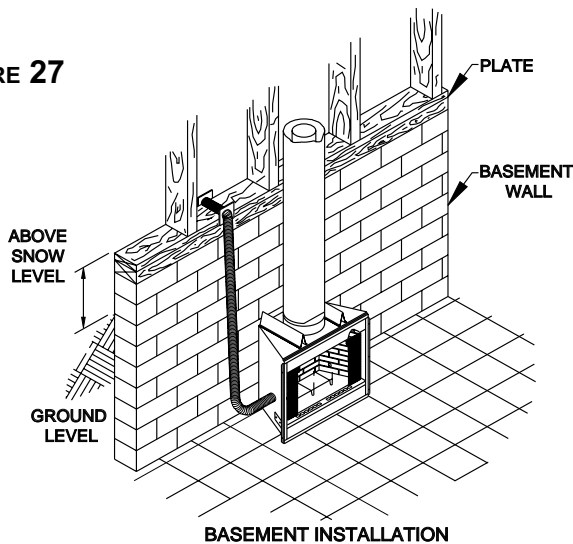

COMBUSTION AIR ASSEMBLY

MODEL AK-4 COMBUSTION AIR ASSEMBLY

1. Remove the cover plate from the 4-inch outlet opening location on the left or right outside of the fireplace. DO NOT remove the cover if the outside air will not be connected.
2. Place the insulation ring between the AK-4 starting collar and fireplace wall and place the starting collar (4 inch) into the hole on the side of the fireplace. Fasten it in place with the four sheet metal screws provided. Figure 24.
3. Cut a 6-inch diameter opening for model AK-4 in the outside wall covering where the outside vent is to be located. Figure 25.
4. Select and cut a piece of duct sufficient length to attach to the fireplace and protrude at least three inches beyond the face of the wall to which the AK-4 inlet air vent will be attached. The duct may be cut with a standard pocket knife (use FP-4 U duct for maximum efficiency and safety). Do not use a combustible duct. Always use UL Listed Class 0 or 1 duct material.
5. If the duct is the insulated type, push the insulation back from one end of the duct approximately two inches. Figure 26.
6. Slip the exposed end of the duct over the starting collar on the fireplace.
7. Using the sheet metal screws provided, secure the duct end to the collar attached to the fireplace.
8. Nail or screw the combustion air assembly to the surface of the wall.

NOTE: If the wall covering is brick or stone, use appropriate masonry fasteners. Mount the combustion air assembly with "TOP" upward to prevent cold air from entering through the wall. If it is necessary to splice the duct, a model 403-duct connector should be used to splice duct sections.

GAS APPLIANCE INSTALLATION

WARNING: Improper installation or operation of a gas appliance in this fireplace can allow unburned gas to leak out which will cause a fire or explosion hazard, or the release of poisonous carbon monoxide into the dwelling which can cause serious injury or death to its inhabitants. To reduce these risks to a minimum, the following important notices and instructions should be read and followed carefully.

IMPORTANT NOTICES:

1. The provision for a gas line is intended for connection to a decorative gas appliance which has an automatic shutoff device and complies with the Standard for Decorative Gas Appliances for Installation in Vented Fireplaces, ANSIZ21.60. If a decorative gas appliance is installed, it must be installed in accordance with the National Fuel Gas Code, ANSIZ223.1.

CAUTION: "When a decorative gas appliance is installed, the fireplace damper must be set in the fully open position at all times."

GAS APPLIANCE INSTALLATION

CAUTION: If an unvented gas appliance is installed in the fireplace, the gas appliance must only be operated with the fireplace glass door fully open (if included). Only unvented gas log set which have been found to comply with the standard for unvented room heaters, ANSI/IAS/AGA Z21.11.2, are to be installed in this fireplace.

WARNING: Do not operate an unvented gas log set in this fireplace with the chimney removed. The installer of the fireplace and gas appliance must describe the operation of the fireplace and appliance to the people who will be operating them and leave all instruction manuals with the operator of the appliance.

2. An approved gas shut off valve must be located outside the fireplace in an area accessible to the users of the fireplace.
3. All gas piping and fitting must be either steel or malleable iron. Unions must be of the ground joint type.
4. Some code authorities prohibit or place restrictions on the use of gas appliances in fireplaces. Check with local code authorities before proceeding with the installation.
5. The gas appliance and all connecting gas piping should only be installed by a licensed gas appliance installer. See Figure 28 for the gas line opening dimensions on the fireplace.
6. The installer should advise the persons who will use the appliance to set the fireplace damper in the full open position when the appliance is in use.
7. See Figures 29 and 30 for acceptable combustible mantel locations if an unvented gas appliance is being installed in the fireplace. See Figure 31 for acceptable combustible mantel location if the fireplace is being installed to burn wood.

The following instructions only apply to passing the gas line through the fireplace wall. Follow the instructions provided by the appliance for the gas line, testing and adjusting it.

1. Locate the recessed area in the side refractory panel as shown by Figure 28.
2. Tap out a round hole in the brick liner with a hammer by tapping lightly on the recessed area.
3. Remove the two screws that hold the cover plates on the jacket wrap and discard the cover plate.
4. Use a screwdriver or similar tool to push the loose insulation out of the tube between the firebox and the outer jacket of the fireplace.
5. Install the gas pipe through the tube between the firebox and jacket.
6. Attach the gas appliance to the gas pipe according to the appliance makers instructions.
7. Pack the insulation removed in step 4 around the pipe to prevent air flowing through the tube either into or out of the firebox.
8. Be sure the gas is turned off at the appliance, then turn the gas on at the cut off valve and test the gas line connections for leaks with soapy water solution or a liquid leak detector. **DO NOT USE A MATCH OR OTHER FLAME SOURCE TO CHECK FOR GAS LEAKS.** If a gas leak is detected, turn the gas off immediately and fix the leak.
9. Proceed with testing the appliance for leaks and adjusting it as required by the manufacturer instructions.

GAS APPLIANCE INSTALLATION

FIGURE 28

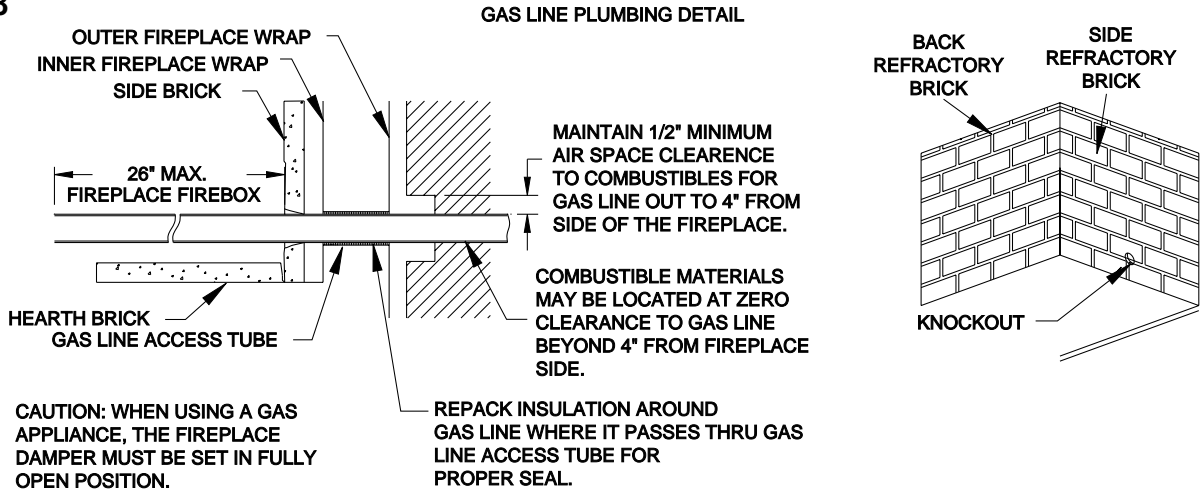

FIGURES 29 AND 30 SHOW ACCEPTABLE COMBUSTIBLE MANTEL LOCATIONS IF AN UNVENTED GAS APPLIANCE IS INSTALLED IN THE FIREPLACE. SEE PART C OF FIGURE 31 FOR ACCEPTABLE COMBUSTIBLE MANTEL LOCATION IF FIREPLACE IS INSTALLED TO BURN WOOD.

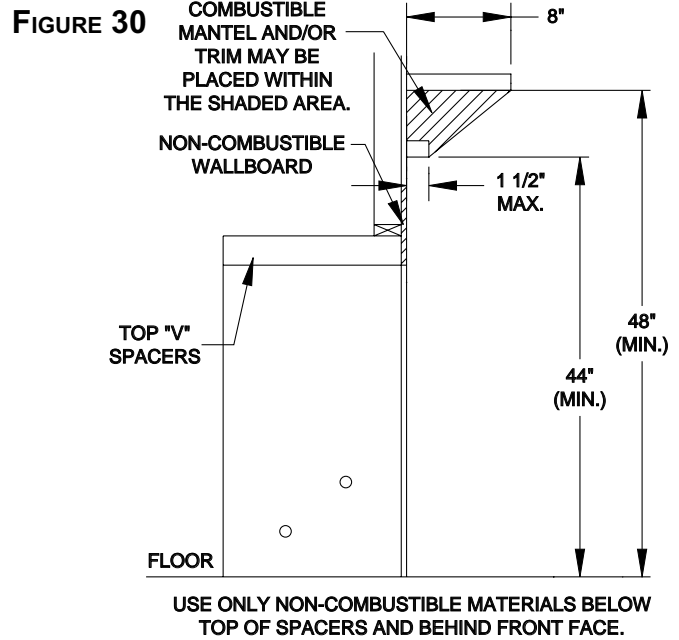
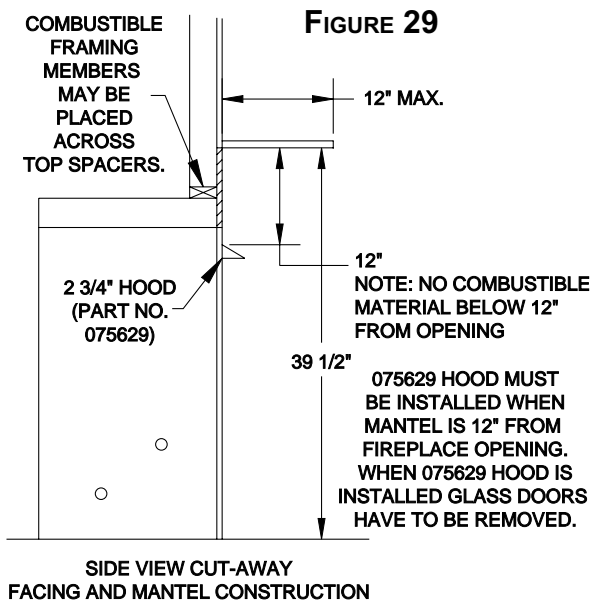

TRIM INSTALLATION

Do not allow the trim materials to extend closer than 3/8 inch to the vertical edges of the firebox opening if you plan to equip the fireplace with glass doors.

The face of your fireplace may be left exposed or trimmed. If trim is installed, be sure it is fastened securely to the face of the fireplace. Any crack between the trim material and the face of the fireplace could pose a fire hazard and impair the proper operation of the fireplace; seal such cracks. See Figure 31. Blocking the fireplace with framing and attaching the base to the supporting floor will reduce the possibility of a crack redeveloping after sealing. **(CAUTION: ACCEPTABLE COMBUSTIBLE MANTEL LOCATION SHOWN BY PART C OF FIGURE 31 IS FOR WOODBURNING FIREPLACE INSTALLATION ONLY. SEE FIGURES 29 AND 30 FOR ACCEPTABLE COMBUSTIBLE MANTEL LOCATIONS WHEN AN UNVENTED GAS APPLIANCE IS INSTALLED IN THE FIREPLACE.)**

TRIM INSTALLATION

Wall ties should be fastened to the face of the fireplace with sheet metal screws and placed in the mortar joints of masonry trim.

FIGURE 31

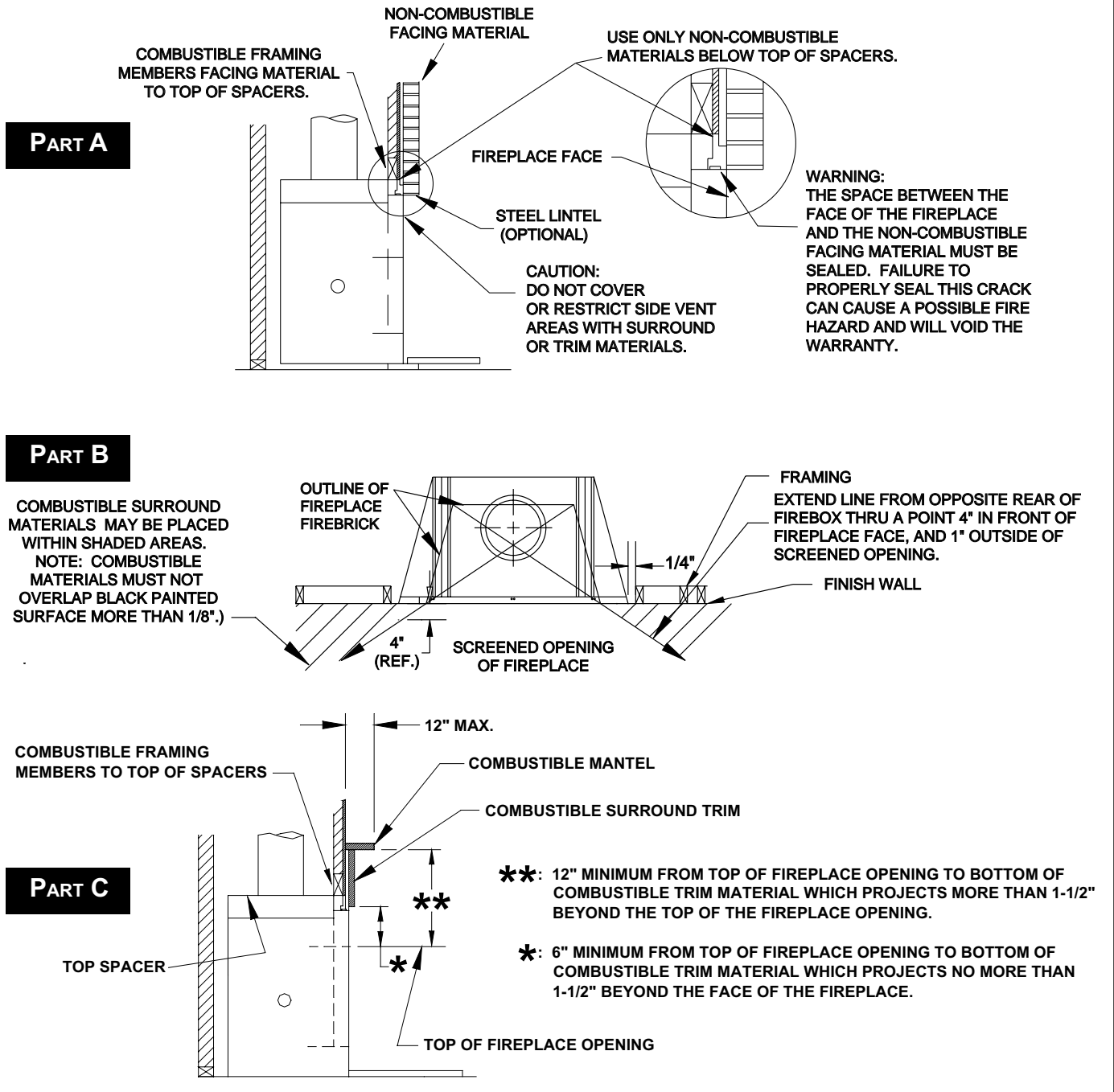

INSTALLATION OF COMBUSTIBLE TRIM MATERIALS ABOVE THE TOP OF THE FIREPLACE OPENING

PART C OF FIGURE 31 SHOWS ACCEPTABLE COMBUSTIBLE MANTEL LOCATION IF FIREPLACE IS INSTALLED TO BURN WOOD. SEE FIGURES 29 AND 30 FOR ACCEPTABLE COMBUSTIBLE MANTEL LOCATIONS IF AN UNVENTED GAS APPLIANCE IS INSTALLED IN THE FIREPLACE. PARTS A AND B OF FIGURE 31 ARE TYPICAL FOR EITHER WOOD OR UNVENTED GAS APPLIANCE INSTALLATION.

GLASS DOOR INSTALLATION AND FAN ACCESSORY

GLASS DOOR INSTALLATION

This fireplace has been tested and listed for use with optional Model GD36P or GD36PB glass doors. For installation of the Models GD36P or GD36PB glass doors, see the instructions provided with the doors.

FAN ACCESSORY

The model BWBC400 and BWBC400I Fireplaces may be equipped with a Model FA2 fan accessory. If the fireplace is to be equipped with the FA2 fan at anytime, the JB1 junction box assembly must be installed on the fireplace as shown by Figures 32 and 33 during the installation of the fireplace. Unless the JB1 junction box is installed at this time, wall finishing materials must be removed to gain access to the side of the fireplace to install the JB1 junction box at a later date. Complete Installation and Operation Instructions are included with the FA2 Fan.

Note: A rectangular switch knockout is provided on the lower right hand face of the fireplace.

FIGURE 32

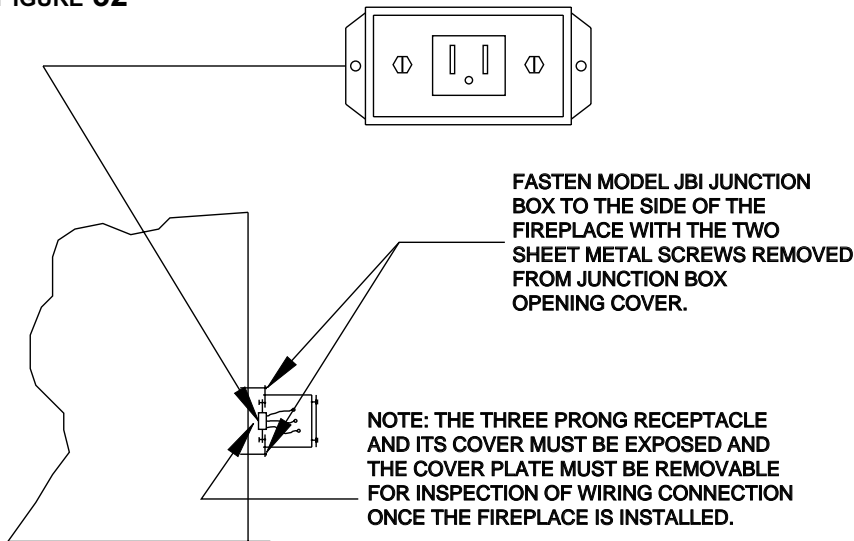

MODEL JBI JUNCTION BOX INSTALLATION

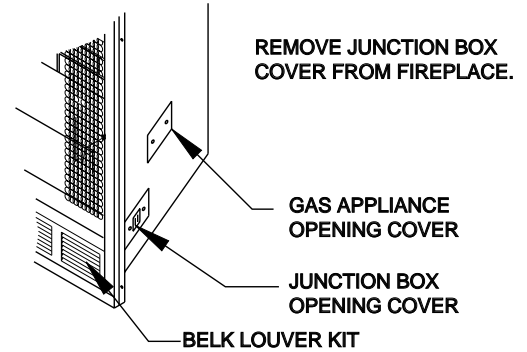
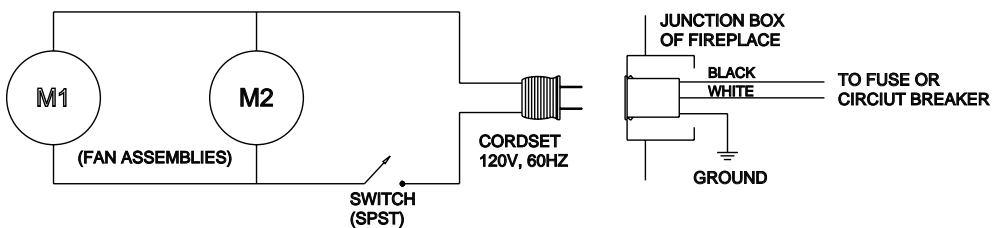

FIGURE 33



NOTE: THE JBI-JUNCTION BOX SHOULD BE INSTALLED AND THE RECEPTACLE WIRED TO THE ELECTRICAL SYSTEM OF THE STRUCTURE AT THE TIME OF INSTALLATION OF THE FIREPLACE OF THE FA2 FAN ASSEMBLY IS TO BE USED.

FIREPLACE OPERATION

WARNING: If a decorative gas appliance is used in the fireplace the fireplace damper must be fixed in an open position. (See additional operation information in section titled "Operation Guidelines".)

ADVANTAGES OF A WOOD BURNING FIREPLACE

These are the practical, ecological advantages of wood as a fuel. Also to be considered is the aesthetic appeal. Most of us consider a wood fire with nostalgia. We enjoy the aroma, and find the flickering light of a cozy hearth conducive to a happy remembrance of things past. Wood has a low ash content. And the little ash that remains after burning is useful in home gardening as a fertilizer and soil conditioner.

WHICH WOODS ARE BEST?

Each wood species offers something different in aroma or heat value, and you should consider your needs and desires before building your fire.

Softwoods, like pine, spruce, and fir are easy to ignite because they are resinous. However, a fire built entirely of softwoods burns out quickly and requires frequent replenishment. While a softwood fire is not too desirable for a long evening, it's fine in the morning when you want quick warmth, or late in the evening when you want a fire that will burn out before you go to bed.

On occasion when a longer fire is desired, it's best to combine softwoods with the heavier hardwoods such as ash, beech, birch, maple, oak and hickory. These hardwood species burn less rapidly, with shorter flames, and produce steady, glowing coals.

For the most pleasing aroma, you'll want to burn the wood of fruit trees such as apple and cherry, or nut trees such as beech, hickory and pecan. Such wood is generally more expensive, but a little combined with other wood, goes a long way. Start your fire with a mixture of softwood and hardwood, then add some fruit or nut wood for nostalgic aroma. Since most woods will not burn well when freshly cut, the wood you purchase should be reasonably dry. The sizes you buy are dictated by the size of your fireplace. Purchase logs that will fit when laid across your grate, and ask that the larger, heavier logs be split. Kindling should be short, easily split lengths of softwood, lumber yard or mill scraps, or twigs and branches gathered from your yard.

HOW TO BUILD A BETTER FIRE

The first three fires should be of moderate size to allow the fireplace to adjust and the bricks to cure before being subjected to larger fires.

First, make sure your room is well ventilated, your damper open and the flue is unobstructed. Then make sure your wood is dry and seasoned. Unseasoned wood burns poorly and coupled with poor ventilation or an obstructed chimney, leads to smoking problems.

If your fireplace is equipped with an outside combustion air assembly, open the combustion air inlet by pushing upward on the lever located above the firebrick on the left side of the firebox.

NEVER USE GASOLINE, GASOLINE-TYPE LANTERN FUEL, KEROSENE, CHARCOAL LIGHTER FLUID, OR SIMILAR LIQUIDS TO START OR "FRESHEN UP" A FIRE IN THIS FIREPLACE. KEEP ALL SUCH LIQUIDS WELL AWAY FROM THE FIREPLACE WHILE IT IS IN USE. USE OF THIS FUEL CAN CAUSE A SERIOUS EXPLOSION.

Prepare your fire by placing two logs on the iron grate or fire basket, and laying the tinder between them. Tinder may be dry scrap paper, twigs, or bark. On top place a small handful of twigs or split softwood kindling. Place more dry logs over this base. Keep logs close together, as narrow air spaces between them promote better drafts, and heat reflected between adjacent surfaces aids in raising and maintaining combustion temperatures.

FIREPLACE OPERATION

You'll need a minimum of three logs, preferably four, to make a good fire. Add kindling and new logs as needed to rekindle a dying fire. New logs should be added at the rear grate after raking the coals toward the front. **Do NOT OVERFIRE THE FIREPLACE.** Overfire conditions may be created by large amounts of kindling, building scraps, or other improper fuels.

Ashes, important because they form a bed of glowing coals, should only be left to accumulate within an inch or two of the bottom of the grate. Excess ashes can be used to check a flaming fire; or to "bank" your fire, cover the logs with ashes. A "banked" fire will hold glowing coals for 8-10 hours, thereby saving a fire for later use.

WOOD VS. FOSSIL FUELS

Compared to fossil fuels, a full cord of dry hickory weighs about two tons and is approximately equal in heating value to a ton of hard coal. On a pound basis, heavy hardwoods have about half the heating value of coal. The tabulation shows the relative densities and heat values of a variety of dry woods. Varieties at the top of the list (Dogwood) burn longer and those near the bottom (White Pine) ignite and burn quicker. A combination of both light and heavy wood is desired.

<u>SPECIES</u>	<u>DENSITY</u>	<u>HEAT VALUE</u>	<u>SPECIES</u>	<u>DENSITY</u>	<u>HEAT VALUE</u>
Dogwood	.70-.79	100-107	Ash	.57-.61	81-82
Hickory	.70-.74	100	Southern Pine	.51-.60	73-81
Oak	.60-.73	86-99	Elm	.50-.59	71-80
Black Locust	.69-.70	95-98	Cherry	.50-.52	70
Beech	.64-.66	89-91	Douglas Fir	.45-.51	64-69
Hard Maple	.58-.65	83-88	Spruce	.41-.44	59
Birch	.55-.64	79-86	Redwood	.33-.40	47-54
Apple	.58-.62	83-84	White Pine	.35-.37	50

A FEW WORDS OF CAUTION

Beware of burning certain material in your fireplace. Among these are plastics, poison ivy twigs and stems, and chemically treated woods such as discarded poles and railroad ties. These not only create air pollution, but can induce extreme irritation for some individuals.

Use hemlock, spruce, juniper and other resinous woods with caution. They contain moisture pockets which, upon heating, "pop" with considerable vigor.

Always use a fire screen. And always "bank" a fire, or at least push all unburned fuel to the rear of the grate before leaving a fire unattended. Do not use this fireplace as an incinerator.

Because the termination of the chimney above the roof is exposed to wind and cold and the pressure changes these and other environmental conditions may cause, a sufficient chimney draft may be hard to establish at times. At other times the draft may be sufficiently disrupted to cause smoke to spill from the fireplace opening. If problems with chimney draft occur, help start chimney draft before you build a fire by holding a piece of burning paper near the flue opening at the top of the firebox to preheat the chimney. If smoke spills from the fireplace opening after the fire is burning, open a window on the up wind side of the house that is far enough away from the fireplace that the wind will not blow across the fireplace opening, push the burning wood as near the back of the fireplace as possible, and if the fireplace is equipped with glass doors, close them.

DO NOT LEAVE CHILDREN OR PHYSICALLY OR MENTALLY HANDICAPPED, OR SENILE PERSONS ALONE WITH A BURNING FIREPLACE.

MAINTENANCE AND SAFETY

FUEL STORAGE

Wood can be dried sufficiently for burning within a few weeks if protected from rain in a low humidity area. It is far better to cut wood and allow it to dry for a year. In all cases, the wood should be stacked so that both ends of the sticks are exposed to the air and protected from rain. The drier the wood, the more usable heat produced by the fire and less likely rapid accumulation of soot and creosote within the chimney is to occur. See the section of this manual concerning chimney maintenance for information concerning the hazards of soot and creosote accumulation. Small quantities of wood required for fire tending must be kept at least 30 inches from the fireplace.

DISPOSAL OF ASHES

Ashes should be placed in a metal container with a tight fitting lid. The closed container of ashes should be placed on a noncombustible floor or on the ground well away from all combustible materials pending final disposal. If the ashes are disposed of by burial in soil or otherwise locally dispersed, they should be retained in the closed container until all cinder has thoroughly cooled. Ashes should never be placed in a container with combustible materials.

CHIMNEY MAINTENANCE

Creosote, Formation and Need for Removal: When wood is burned slowly, it produces tar and other organic vapors, which combine with expelled moisture to form creosote. The creosote vapors condense in the relatively cool chimney flue of a slow-burning fire. As a result, creosote residue accumulates on the flue lining. When ignited, this creosote makes an extremely hot fire.

The chimney should be inspected at least twice a year during the heating season to determine if a creosote buildup has occurred.

If creosote has accumulated it should be removed to reduce the risk of a chimney fire.

The chimney cap can be removed for inspection, maintenance and cleaning by removing three screws from the support legs and lifting upward.

When the fireplace is first in use, inspect the chimney frequently and clean the chimney any time an accumulation is observed on the flue walls. The frequency of these inspections can be increased or reduced appropriately after a pattern of accumulation has been established. Please note, however, that changes in the outside environmental conditions such as temperature and humidity or changes in the operation of the fireplace can lead to rapid buildup of soot and/or creosote.

To clean the chimney, obtain the services of a qualified and reputable chimney sweep, or remove the accumulation with brushes on wooden or fiberglass poles. Do not use metal pipes, chains, wires, etc., to clean the chimney because such items can scratch the surface of the stainless steel flue which can shorten the life of the flue and provide a rough surface for soot particles to attach to.

Be sure to cover nearby furnishing and arrange some method of catching soot and creosote particles that may fall during the chimney cleaning process. If glass doors are installed on the fireplace, they should be closed. Extra caution must be used to avoid damage to the flue damper during the cleaning process.

In addition to checking and cleaning the chimney on a regular basis, be sure to inspect the chimney before starting a fire at the beginning of each heating season. Make sure the chimney is clear from any accumulation of soot, creosote or any other debris, and that all joints are intact.

Monessen Hearth Systems does not recommend chemical cleaners because some may contain elements that corrode the metal parts of the chimney or fireplace.

MAINTENANCE AND SAFETY

FIREPLACE MAINTENANCE

At the end of each heating season or when the fireplace will not be in use for an extended time, the ashes should be removed and the hearth area should be swept as clean as is practical. The slow absorption of moisture into the ashes over a long period of time could cause a condition which would be corrosive to the metal fireplace parts.

At the beginning of each heating season, always operate the flue damper and make sure it has not become stuck from soot, creosote, etc., during the period of inactivity.

Keep the lower and upper grille panels clean and free from dirt and lint accumulation at all times to get the maximum efficiency from your fireplace.

As you use the fireplace, expansion and contraction will cause minor cracking of the hearth, back, and side refractory materials. This is normal and unavoidable. If the cracks become large enough or parts dislodge and metal behind the refractory is exposed, the refractory panels should be replaced with new panels that can be obtained from you Monessen Hearth Systems fireplace dealer.

GLASS DOOR MAINTENANCE

For glass door maintenance, see instructions provided with the glass doors.

CHECKLIST OF DO'S AND DONT'S

DO'S

1. Do check with local building officials to be sure the installation of the fireplace complies with all building codes and requirements and obtain required building permits. Do plan your installation with safety as your primary consideration.
3. Do use only the prescribed material and parts for the installation of the fireplace.
4. Do insulate the exterior walls surrounding the fireplace to prevent excessive heat loss from the fireplace.
5. Do trim the face of the fireplace only with noncombustible materials.
6. Do attach the noncombustible face trim material firmly to the face of the fireplace.
7. Do block in or fasten the fireplace to prevent the possibility of the fireplace shifting out of position.
8. Do connect the air circulation blower to a properly grounded and fused electrical circuit.
9. Do enclose the chimney where it passes through living spaces or spaces accessible for storage purposes to prevent contact with and possible damage to the chimney.
10. Do install firestop spacers at each ceiling level when the chimney is installed in a multistory building.
11. Do install the proper chimney cap or chimney housing on the chimney to prevent rain and debris from entering the chimney.
12. Do keep all flammable liquids, gases and pressurized containers away from the fireplace.
13. Do check the fireplace for proper adjustment and operation before leaving it unattended for long periods of time.
14. Do inspect and clean the fireplace chimney regularly.
15. Do keep the fire screens closed when the fireplace is left unattended to minimize the danger of sparks popping out of the fireplace.
16. Do use the grate furnished with and for this fireplace.
17. Do start a fire only with paper, kindling or solid composition fire starters specifically designed for starting a fire. The use of liquid fire starter can cause an explosion within the fireplace.
18. Do place all ashes in a metal container with a tight fitting lid and place them on a noncombustible surface well away from other combustible materials until they have completely cooled.
19. Do store your fuel supply at a distance equal to or greater than the spacing recommended for combustible materials from the fireplace.

MAINTENANCE AND SAFETY

20. Do not build fires of moderate intensity in the fireplace for the first three fires to allow materials to adjust and cure before being subjected to the intense heat of a large fire.

DON'T'S

1. Don't allow other installations or operation considerations to take priority over safety considerations.
2. Don't attempt to use the fireplace until the installation is complete.
3. Don't use unlisted parts and accessories with the fireplace except for special flashings fabricated locally.
4. Don't use damaged parts or accessories with this fireplace.
5. Don't install the fireplace in an exposed or uninsulated area.
6. Don't install the fireplace over carpeting.
7. Don't install the fireplace on a poorly constructed base or fail to fasten down or attach the fireplace to prevent it from shifting out of position.
8. Don't create or allow a crack to develop between the metal face of the fireplace and noncombustible trim.
9. Don't use power blowers or air circulation systems with this fireplace that are not specifically recommended by Monessen Hearth Systems .
10. Don't connect accessory air circulation blowers to improperly fused or ungrounded electrical circuits.
11. Don't install the fireplace where flammable or explosive liquids or vapors are likely to be present.
12. Don't neglect all the considerations mentioned in this manual concerning clearances to combustibles, spacing from obstructions and proper chimney height when selecting the location and installing the chimney.
13. Don't allow insulating materials to contact the chimney.
14. Don't neglect to apply caulking or mastic to the required joints of the flashing and between the flashing roof.
15. Don't dry clothing or other articles near the fireplace.
16. Don't store or place flammable liquids, gases or pressurized containers near the fireplace.
17. Don't neglect to instruct all responsible persons in the proper and safe operation of the fireplace.
18. Don't fail to instruct all persons, especially children and elderly persons, concerning the hazards of improper operation and unauthorized tampering with the fireplace.
19. Don't use this fireplace to burn paper, cardboard, or other debris.
20. Don't neglect to inspect and clean the chimney regularly.
21. Don't operate the fireplace with the glass fire screen doors partially open. The doors should always be fully open or fully closed.
22. Don't use gasoline, kerosene, engine oil, charcoal lighter fluid, or other flammable liquids to start or intensify a fire. Using these and similar materials can cause an explosion within the fireplace.
23. Don't store fuel supply closer to the fireplace than the minimum spacing required for combustible materials.
24. Don't subject the fireplace to the intense heat of a large fire the first three times the fireplace is used, but build moderate fires to allow the materials to cure and adjust.
25. Don't clean the chimney with metallic devices or chemical cleaners.
26. Don't use the fireplace or chimney for venting wood or coal burning heaters or inserts unless approved in writing by Monessen Hearth Systems .
27. Don't put combustibles within 24 inches of the fireplace opening

"WARNING: IF NOT INSTALLED, OPERATED AND MAINTAINED IN ACCORDANCE WITH THE MANUFACTURERS INSTRUCTIONS, THIS PRODUCT COULD EXPOSE YOU TO SUBSTANCES IN FUEL OR FROM FUEL COMBUSTION WHICH CAN CAUSE DEATH OR SERIOUS ILLNESS AND WHICH ARE KNOWN TO THE STATE OF CALIFORNIA TO CAUSE CANCER, BIRTH DEFECTS OR OTHER REPRODUCTIVE HARM. ALSO, OPERATION, INSTALLATION AND SERVICING OF THIS PRODUCT COULD EXPOSE YOU TO AIRBORNE PARTICLES OF GLASS WOOL FIBERS KNOWN TO THE STATE OF CALIFORNIA TO CAUSE CANCER THROUGH INHALATION."

PARTS DIAGRAM AND LIST

All repair part orders should be placed through your local dealer. To ensure prompt and accurate service, please provide the following information when placing a repair part order: Model number of your Appliance, Part Name, Part Number, and Quantity of parts needed.

Technical Service Department
2813 W. Mall Drive, Unit B.
Florence, Alabama 35630.
Tel. - 1-866-500-5671
www.monessenhearth.com

BWB400/BWB400I MODEL FIREPLACE

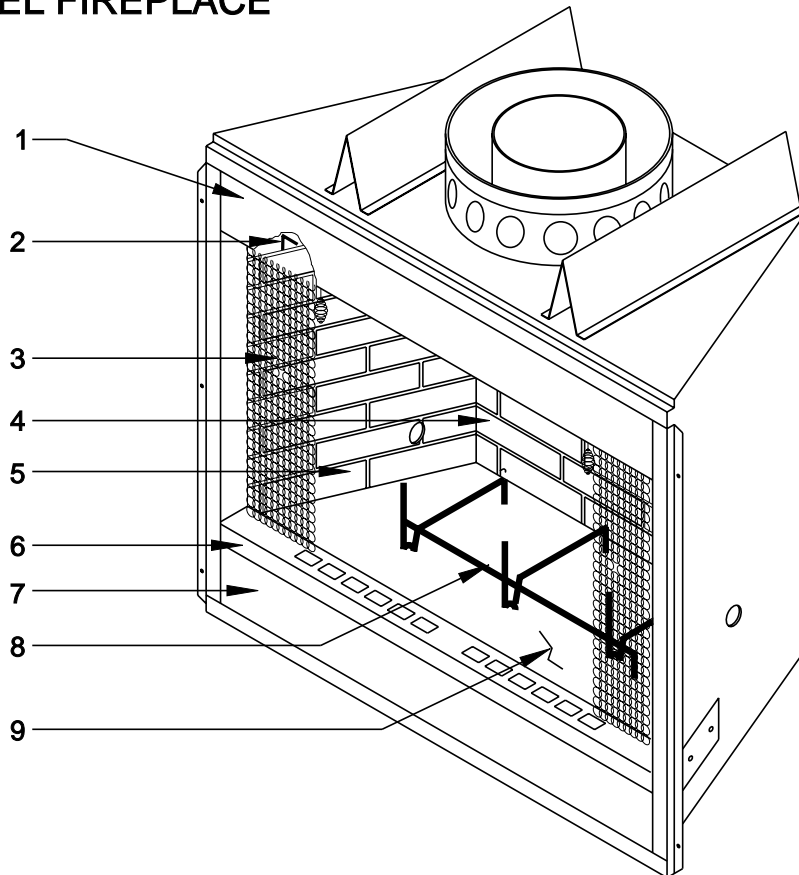

KEY NO.	PART NAME	QTY.	PART NUMBER
1	UPPER PANEL PNTD. ASSY.	1	076418
2	WELDMENT AIR DOOR ROD	1	031867
3	FIRESCREEN PANELS	2	070940
4	FIREBRICK BACK ASSY.	1	031871
5	FIREBRICK SIDE ASSY.	2	031872
6	LEDGE HEARTH PNTD. ASSY.	1	077002
7	LOWER PANEL PNTD. ASSY.	1	061876
8	GRATE PNTD. ASSY.	1	055119
9	HEARTH REFRACTORY ASSY.	1	031873

PARTS DIAGRAM AND LIST

All repair part orders should be placed through your local dealer. To ensure prompt and accurate service, please provide the following information when placing a repair part order: Model number of your Appliance, Part Name, Part Number, and Quantity of parts needed.

Technical Service Department
2813 W. Mall Drive, Unit B.
Florence, Alabama 35630.
Tel. - 1-866-500-5671
www.monessenhearth.com

BWBC400/BWBC400I MODEL FIREPLACE

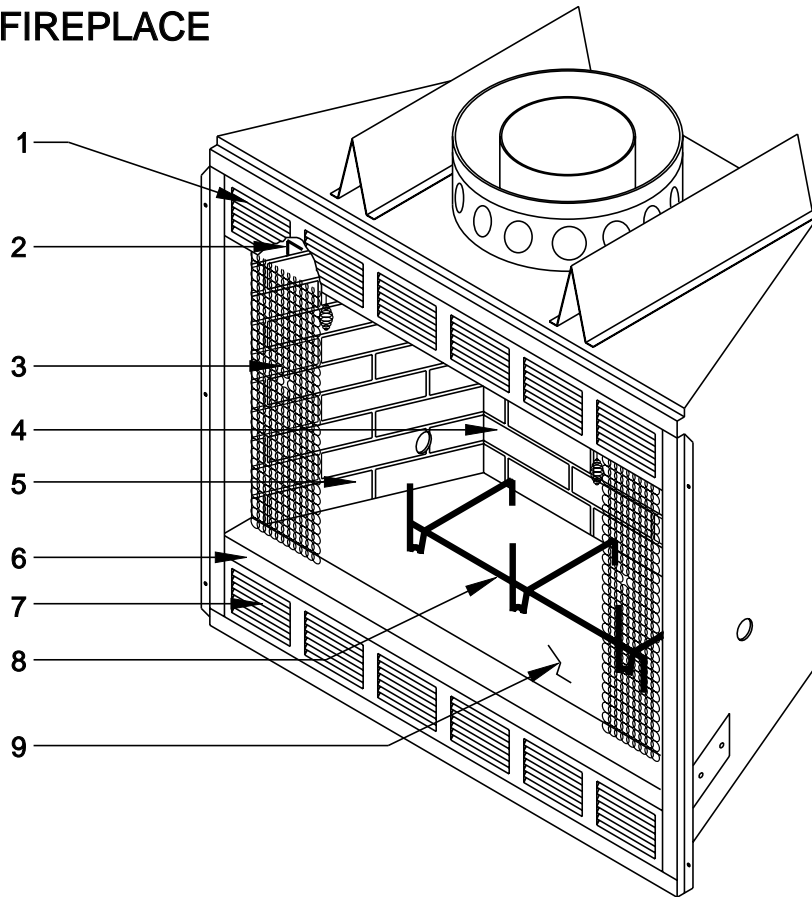

KEY NO.	PART NAME	QTY.	PART NUMBER
1	UPPER GRILLE PNTD. ASSY.	1	077000
2	WELDMENT AIR DOOR ROD	2	031867
3	FIRESCREEN PANELS	1	070940
4	FIREBRICK BACK ASSY.	1	031871
5	FIREBRICK SIDE ASSY.	2	031872
6	LEDGE HEARTH PNTD. ASSY.	1	077151
7	LOWER GRILLE PNTD. ASSY.	1	020362
8	GRATE PNTD. ASSY.	1	055119
9	HEARTH REFRACTORY ASSY.	1	031873

LIMITED WARRANTY

FACTORY-BUILT FIREPLACE AND COMPONENTS (EXCEPT BLOWERS)

WHAT IS COVERED AND FOR HOW LONG

- **FIVE-YEAR COVERAGE** - For five years from the date this fireplace and components are first purchased for use, Monessen Hearth Systems will, at its option, repair or replace any defective part of this fireplace or components, or refund to you a sum not to exceed the factory retail price in effect at the time of purchase.
- **TEN-YEAR COVERAGE** - From the sixth through the tenth year following the date this fireplace or accessory is first purchased for use, Monessen Hearth Systems will make available to you, at our factory, a free replacement for any defective part in this fireplace or accessory.
- **TWENTY-FIVE-YEAR AVAILABILITY OF REPLACEMENT PARTS** - From the eleventh through the twenty-fifth year following the date this fireplace or accessory is first purchased for use, Monessen Hearth Systems will make available at our factory replacement parts for this fireplace or accessory, which you may purchase for the list price current at the time your purchase order is received.

WHAT IS NOT COVERED

This limited warranty does not cover:

- Transportation or shipping cost.
- The cost of a service call to diagnose trouble.
- Painted surfaces.
- Damage or defect caused by improper installation, accident, misuse, abuse or alteration.
- Poor ventilation of smoke or gases caused by air-conditioning and heating systems, exhaust fans, or pressure differentials produced by wind.
- Broken glass components
- Cracks in ceramic and castable parts that do not affect safe operation.
- We do not warrant this fireplace to be in compliance with your local building code. Building codes vary greatly throughout the country, and you should determine whether your local building code contains restrictions on the use of this fireplace before you purchase it.
- Blowers or fans, which are warranted separately.
- Heat loss due to the passage of heat or air through or around the fireplace.

Also, under our five year coverage, we do not pay the cost of removal and replacement of any portion of the structure in which the fireplace is situated, made necessary by the repair, removal or re-installation of the fireplace.

And under our twenty-five year warranty of availability of replacement parts, we only promise to maintain a supply of replacement parts at our factory for you to purchase.

LIMITATIONS AND EXCLUSIONS

1. No one has authority to add to or vary this limited warranty, or to create for Monessen Hearth Systems any other obligation of liability in connection with this fireplace and accessory.
2. Monessen Hearth Systems SHALL NOT BE LIABLE FOR INCIDENTAL, CONSEQUENTIAL, SPECIAL OR CONTINGENT DAMAGES YOU MIGHT SUFFER AS A RESULT OF ITS BREACH OF THIS WRITTEN WARRANTY OR ANY IMPLIED WARRANTY. Some states do not allow the exclusion of limitation of incidental or consequential damages, so the above limitations may not apply to you.
3. This warranty applies only to the original purchaser of the fireplace or to the original owner of the dwelling when the fireplace is installed in a new dwelling and may not be transferred.
5. This warranty applies only to a fireplace sold and used in the United States.

LIMITED WARRANTY

YOUR DUTIES

This fireplace must be installed by a qualified installer according to your local building codes and installation instructions and operated according to the owner's instructions. You must keep an invoice, canceled check or payment record to verify the purchase date of the fireplace.

IF YOU HAVE A PROBLEM WITH YOUR FIREPLACE OR COMPONENT

1. Contact your nearest dealer. If you cannot locate your dealer, call or write Monessen Hearth Systems as indicated below.
2. If you do not receive satisfactory service from the dealer within a reasonable time, write Monessen Hearth Systems and include the date you purchased your fireplace or component, its serial number, and details of the problem you are having.

**Technical Service Department
2813 W. Mall Drive, Unit B.
Florence, Alabama 35630.
Tel. - 1-866-500-5671
www.monessenhearth.com**

This warranty gives you specific legal rights, and you may also have other rights which vary from state to state.

NOTES

This page intentionally left blank.

NOTES

This page intentionally left blank.

ATTENTION

**APPLIANCE
INSTALLER**

**PLEASE RETURN THESE OPERATING
AND INSTALLATION INSTRUCTIONS
TO THE CONSUMER.**

MONESSEN HEARTH SYSTEMS

BWB500, BWB500I, BWBC500 AND BWBC500I RESIDENTIAL FIREPLACES INSTALLATION, OPERATION AND MAINTENANCE MANUAL

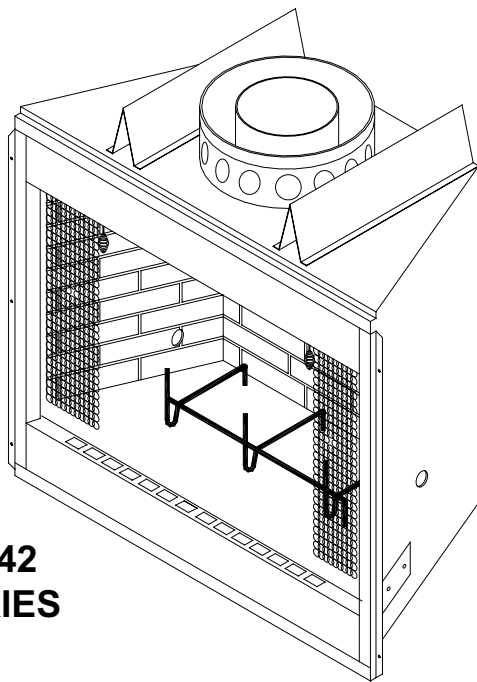

**SF42
SERIES**

42 INCH BUILT-IN WOOD BURNING FIREPLACES.
(GLASS DOORS, FAN ASSEMBLY, AND OUTSIDE
COMBUSTION AIR KIT AVAILABLE.)

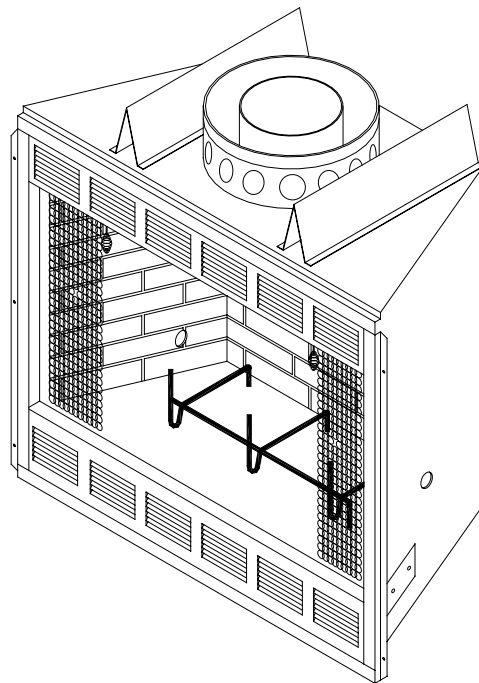

**SCF42
SERIES**

THESE FIREPLACES ARE U. L.[®] LISTED FOR USE
WITH "S" SERIES CHIMNEY SYSTEM COMPONENTS.

ONLY UNVENTED GAS LOG SETS WHICH HAVE BEEN FOUND TO COMPLY WITH THE STANDARD FOR UNVENTED ROOM HEATERS ANSI Z21.11.2 ARE TO BE INSTALLED IN THESE FIREPLACES. WHEN AN APPROVED ANSI Z21.11.2 UNVENTED ROOM HEATER IS INSTALLED IN ONE OF THESE FIREPLACES, AN H2853 CANOPY MUST ALSO BE INSTALLED.

**WARNING: DO NOT OPERATE AN UNVENTED GAS LOG
SET IN ANY OF THESE FIREPLACES WITH THE CHIMNEY REMOVED.**

CONGRATULATIONS!

You have chosen a fine woodburning fireplace. These fireplaces have been designed and manufactured for years of heating and viewing enjoyment. Please take time to read this entire manual before installing or operating your fireplace.

TABLE OF CONTENTS

Listing And code Approvals.....	2
Important Information.....	3
Operation Guidelines.....	4
Clearances.....	5-6
Fireplace Location.....	7
Installation Preparation.....	8-9
Floor Protection.....	10-11
Fireplace Components.....	12-13
Fireplace Installation.....	14
Chimney Installation.....	15-16
Chimney Offset Installation.....	17-18
Chimney Cap Installation.....	19-20
Chimney Cap Chase Installation.....	21
Outside Combustion Air Precautions and Recommendations	22-23
Combustion Air Assembly.....	24
Gas Appliance Installation.....	25-26
Trim Installation.....	27
Glass Door Installation and Fan Assembly.. ..	28
Fireplace Operation.....	29-30
Maintenance and Safety Instructions.....	31-33
Repair Part Diagrams and Lists.....	34-35
Warranty.....	36-37

LISTING AND CODE APPROVALS

The instructions contained in this manual provide the information necessary to install this fireplace in accordance with Underwriter's Laboratories requirements and in compliance with the National Fire Protection Association Standard No. 211. Some codes may require the fireplace and chimney be electrically grounded. Before beginning the installation, you should check with local building officials to obtain required permits and assure compliance with local regulations and codes. If you encounter problems with code requirements, contact your dealer for assistance.

This fireplace is listed by Underwriters Laboratories, Inc. to U.L. 127-standard for factory-built fireplaces. The design of this fireplace and these instructions complied with applicable safety standard for a factory built fireplace in effect at the time the fireplace was manufactured. You should be aware, however, that failure to install, operate, and maintain this or any other factory built fireplace properly can result in a house fire or other occurrences that could cause deaths, injuries, and property damages. It is very important that the persons installing and/or supervising the installation of this fireplace have appropriate skills in using the tools and techniques required; and reading and comprehension skills sufficient to read and follow these instructions. These instructions contain warnings, cautions, and notes to emphasize important safety information. To assure that safe and satisfactory service is received from this fireplace, please read the following special notices and all the contents of this manual.

IMPORTANT INFORMATION

1. Read these instructions entirely before beginning any part of the installation. Save these instructions for any future repairs.
2. Use these instructions as a guide during the installation of the fireplace.
3. Be sure these instructions become the property of and are reviewed by all future users of this fireplace to encourage proper operation and maintenance.
4. All the parts used with this fireplace system must be installed in accordance with these installation instructions. Failure to do so may be hazardous and will void the warranty.
5. This fireplace and accessories should not be altered in any way that is not specifically recommended in this manual.
6. Refer to your local building code for local requirements pertaining to installation of factory-built fireplaces. Monessen Hearth Systems fireplaces are intended for installation and use according to standard NFPA NO.211 of the National Fire Protection Association.
7. This fireplace must not be installed with a masonry flue.
8. This fireplace and chimney should not be used for venting a wood or coal burning heater or fireplace insert.
Warning: Do not install a separate solid fuel insert or gas fireplace insert into this fireplace and chimney system without written authorization from Monessen Hearth Systems.
9. Warning: Do not pack required air spaces with combustible material or insulation not specifically recommended for use in such areas.

INTENDED PRODUCT USAGE

The fireplace is designed to sit directly on a combustible floor. The fireplace must be installed with clearances to combustible building materials specified in this manual. Only parts manufactured by Monessen Hearth Systems and labeled for use with the fireplace should be used in the installation of this fireplace except for special roof flashings that may be fabricated locally. The use of improper parts in the installation can be hazardous and voids the warranty offered by Monessen Hearth Systems. This fireplace is designed to burn wood. This fireplace is not designed to burn coal, unplumbed liquid fuels, unplumbed gaseous fuels or household refuse. Any attempt to burn these fuels in the fireplace can be hazardous. This fireplace is intended for supplemental heating only and is not intended for use as a primary heating system. For use with Solid Wood Fuel, UL Classified Processed Solid Fuel Fire Logs, or Certified Decorative Gas Appliance. This fireplace is not designed for installation in a mobile home without a vented attic space. It may be installed in a manufactured home which incorporates a vented attic space provided that it is equipped with GD42B or GD42PB glass doors, AK6 outside combustion air kit, SVT firestop thimble, and the minimum installed height from floor to flue outlet is 13'6".

“Do not use a fireplace insert or other product not specified for use with this fireplace.”

Warning: Failure to heed usage warnings may cause a fire hazard and will void the Warranty.

IMPROPER INSTALLATION

Improper installation or use of this fireplace will void the warranty and can cause:

1. Damage to the fireplace from overheating.
2. Hazardous temperatures to develop on combustible materials adjacent to the fireplace or chimney.
3. The emission of smoke, sparks or hazardous gases into the dwelling.
4. Leakage of rain water into the dwelling.

OPERATION GUIDELINES

As wood is burned in the fireplace, room air enters the lower louvered panel of models BWBC500 and BWBC500I, or the bottom/side vents on models BWB500 and BWB500I circulates around the firebox. This air circulation cools the firebox and must not be blocked or restricted in any manner. Blocking the air flow can cause a fire hazard.

When a AK4 combustion air assembly and a combustion air duct are attached to the connecting point on the left side of the fireplace, combustion air may enter the firebox through a dampered opening behind the left side panel. This feature reduces the room air used for combustion and prevents excessive heat loss from the room. When the fireplace is in use, this damper should be open. When the fireplace is not in use, the damper should be closed to prevent cold air from entering the firebox. The combustion air damper is open when the lever, located on the left side of the firebox near the top of the left firebrick, is up and closed when the lever is down.

Outside air for combustion is optional unless required by federal, state or local building codes. See the section of this manual providing the instructions for installation of the combustion air assembly. The design of the fireplace allows the routing of the combustion air duct downward or horizontally to obtain the outside combustion air. This permits flexibility in planning your installation. See Figure 27 for typical installation methods. Review the precautions and recommendations in this manual pertaining to outside combustion air installation.

Glass doors should be installed to receive the maximum benefit from your fireplace. For large fires, the maximum heating benefit from the fireplace will be obtained with the doors open due to the high amount of radiant heat being emitted out of the front opening of the fireplace. With a small fire, or before retiring in the evenings, it is best to operate the fireplace with the doors closed to prevent excessive room air from being drawn up the chimney. When the doors are open, the mesh screens should be closed to help keep burning embers from popping out of the firebox.

The fireplace also is equipped with a flue damper, which must be open when the fireplace is in use. The flue damper control lever is located behind the upper panel and may be locked closed by turning the damper rod and latching it over the clip provided. The counterweighted damper is operated by simply pushing up to open or pulling down to close the damper. When the fireplace is not in use, the damper should be closed to prevent cold air from entering the chimney as well as preventing warm air in the room from escaping up the chimney. NOTE: It is normal for a small amount of smoke to be released from the upper portion of the fireplace the first few times you use your new Monessen Hearth Systems fireplace. This results from an oil residue on the metal. Open a door or window to allow the smoke to escape.

The grate included with this fireplace helps to appropriately locate and contain the burning wood. Failure to use this grate may cause overheating of parts of the fireplace and allow large pieces of burning wood to roll forward out of the firebox. If the grate becomes warped or damaged, it must only be replaced with Monessen Hearth Systems 035326 grate.

WARNING: Fireplaces equipped with doors should be operated only with the doors fully open or doors fully closed. If doors are left partly open, gas and flame may be drawn out of the fireplace opening, creating risks of both fire and smoke.

All fireplace chimneys are in direct contact with cold air on the exterior of the structure. Consequently, when the fireplace is not in use, cold air can fall down the chimney of the fireplace to cool off the fireplace chase. Therefore, the fireplace chase must be insulated to minimize the risk of cold air infiltration to the home. Even if the fireplace chase is adequately insulated, this cannot completely ensure that cold air infiltration into the structure will be eliminated. Cold air infiltration is a possibility with any fireplace or device that freely communicates with the air on the outside of the structure. Today's homes are more energy-efficient and, therefore, better insulated and tightly constructed. Unfortunately, when air is removed from the house, as by a bathroom fan, or consumed by a furnace, additional air is needed to replace the air consumed. Unless the additional air is supplied, this can cause a negative pressure in the home. When this happens, the house will draw in outside air from the cracks in the windows, down the fireplace flue or other locations of air leakage in the home. Because cold air infiltration may be unavoidable in some structures, Monessen Hearth Systems is not responsible for heat loss or air infiltration through or around the fireplace.

CLEARANCES

FIGURE 1

RESIDENTIAL INSTALLATION

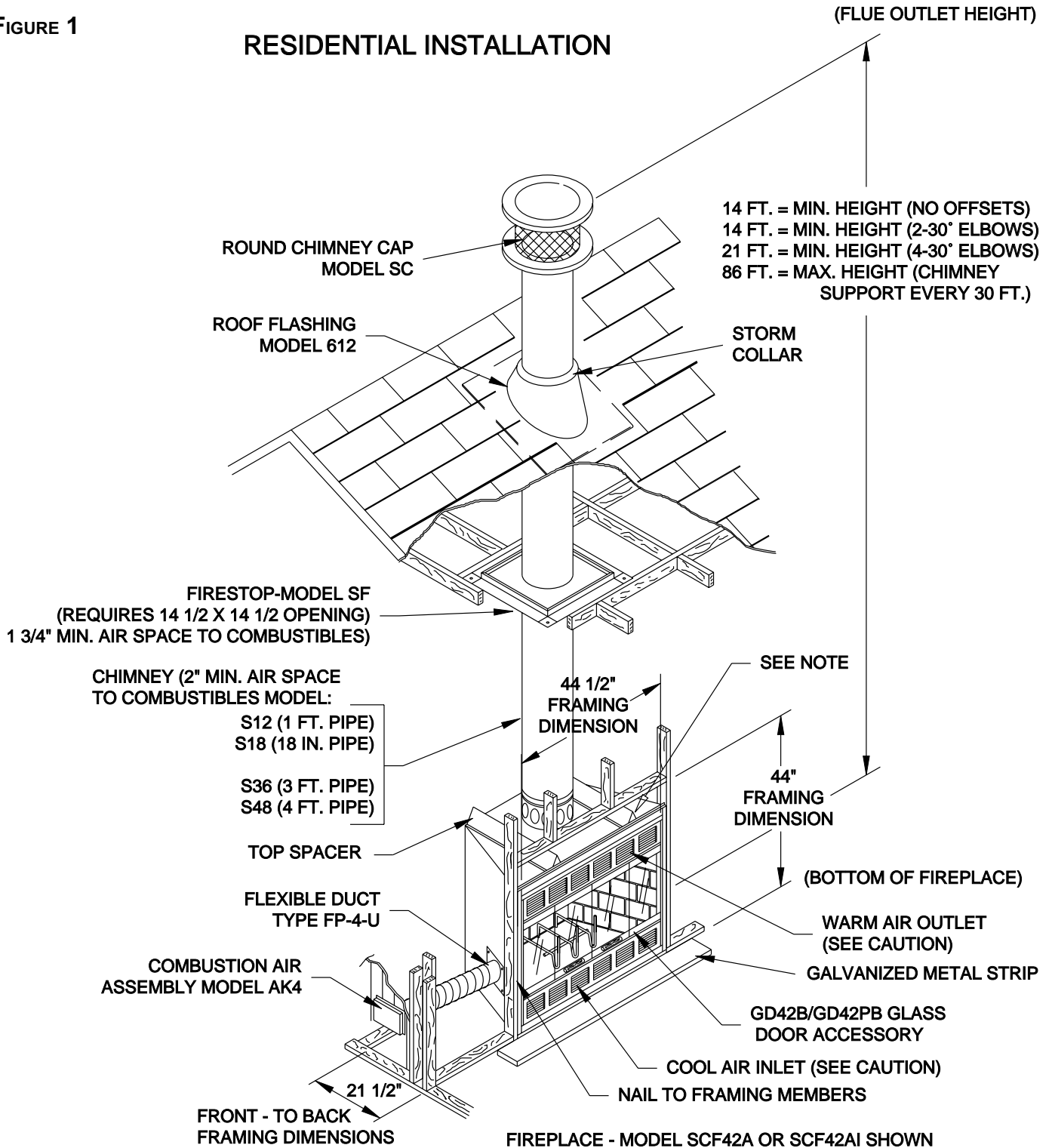

CAUTION: DO NOT BLOCK AIR INLETS OR OUTLETS.

NOTE: COMBUSTIBLE MATERIALS SHOULD NOT BE INSTALLED BELOW TOP SPACER. NON-COMBUSTIBLE MATERIALS SUCH AS BRICK OR TILE MAY BE USED TO TRIM FACE OF THE FIREPLACE BUT SHOULD NOT COVER ANY PORTION OF THE LOUVERED PANEL OR COOL AIR INLET. COMBUSTIBLES MUST NOT OVERLAP THE BLACK PAINTED FACE OF FIREPLACE.

CLEARANCES

FIGURE 2

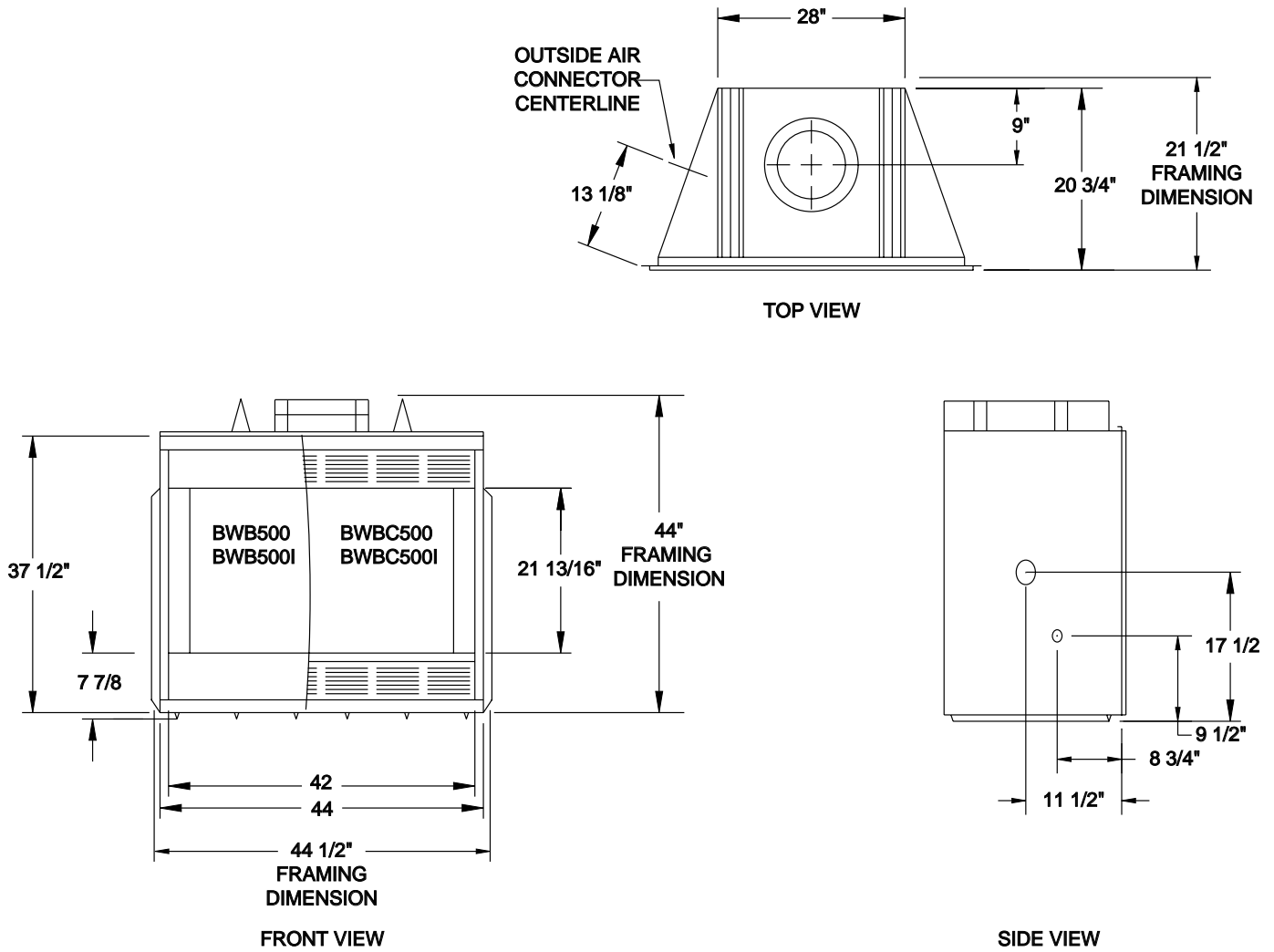
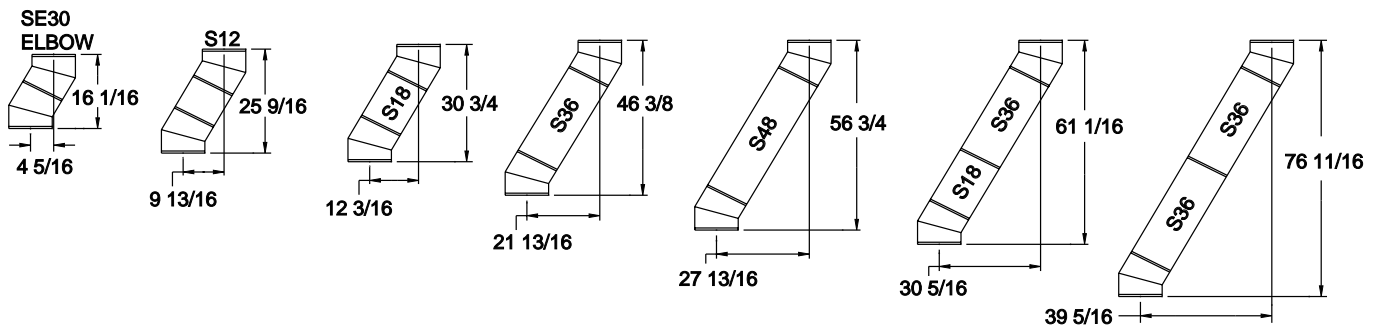

FIGURE 3



NOTE: DIMENSIONS MAY VARY SLIGHTLY DUE TO MANUFACTURING TOLERANCES.

FIREPLACE LOCATION

CAUTION: Do not install fireplace over carpeting.

This fireplace does not weigh more than large pieces of furniture and can normally be located near a load bearing wall without requiring additional foundations or supports. If however, the fireplace is to be trimmed with a heavy stone or brick facing and hearth extension, be sure the supporting structure is adequate.

Figures 4 and 5 provide dimensional details of the fireplace, required spacing to combustibles walls, and some suggested fireplace locations. When selecting a location, choose one that is away from frequently opened doors, central heat outlets or returns, or other places where air movements may disturb the airflow around the fireplace. Air turbulence near the fireplace may cause smoke to spill out of the fireplace opening.

FIGURE 4

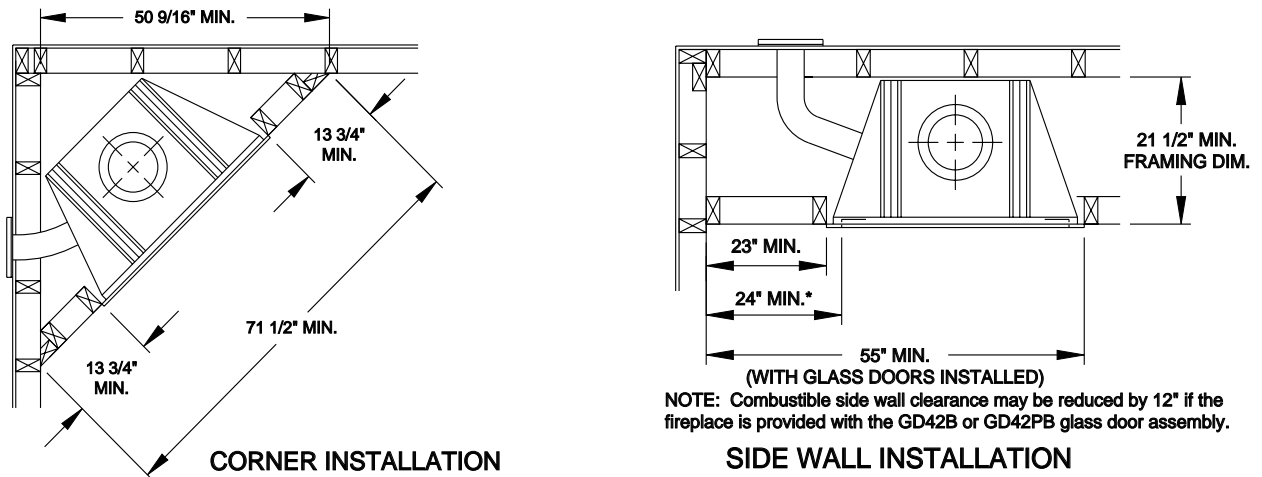
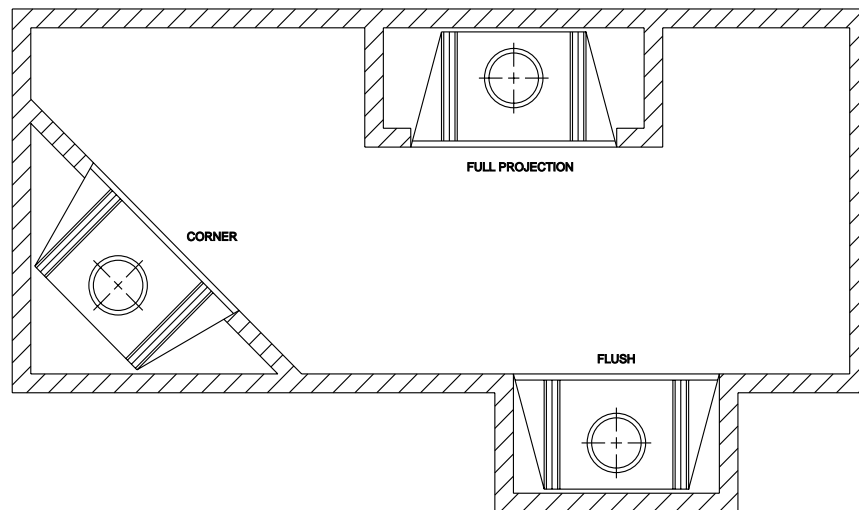

FIGURE 5



INSTALLATION PREPARATION

Survey the planned location for the fireplace for overhead plumbing or electrical wires, etc., that might complicate the installation or endanger persons installing or cleaning the chimney. Avoid a location where the chimney cap will be near abrupt changes in the roof shape, nearby wall or embankments, under or near trees or above the roof of a single story wing of a two story building as shown by Figure 8. All these conditions can cause turbulence or pressure conditions that can cause poor chimney draft and smoke spillage from the fireplace opening. Elbows may be used to offset the chimney to avoid obstructions or to locate the chimney cap in a preferred location. Refer to the sections of this manual pertaining to chimney offsets for instructions on proper elbow use. Poor installation or location of the chimney cap and/or components can cause wind blown rain to enter the chimney.

Be sure the selected location will allow a 14-1/2" square combustible material-free space for the chimney to pass through. If the chimney is to pass through living or storage spaces, be sure there is adequate space to enclose the chimney to avoid personal contact with, or damage to, the chimney. If the fireplace is to be installed on an outside wall, the surrounding walls (chase) should be constructed and insulated as shown by Figure 6. Failure to insulate the fireplace from outside temperatures will cause heat loss through and around the fireplace.

FIGURE 6

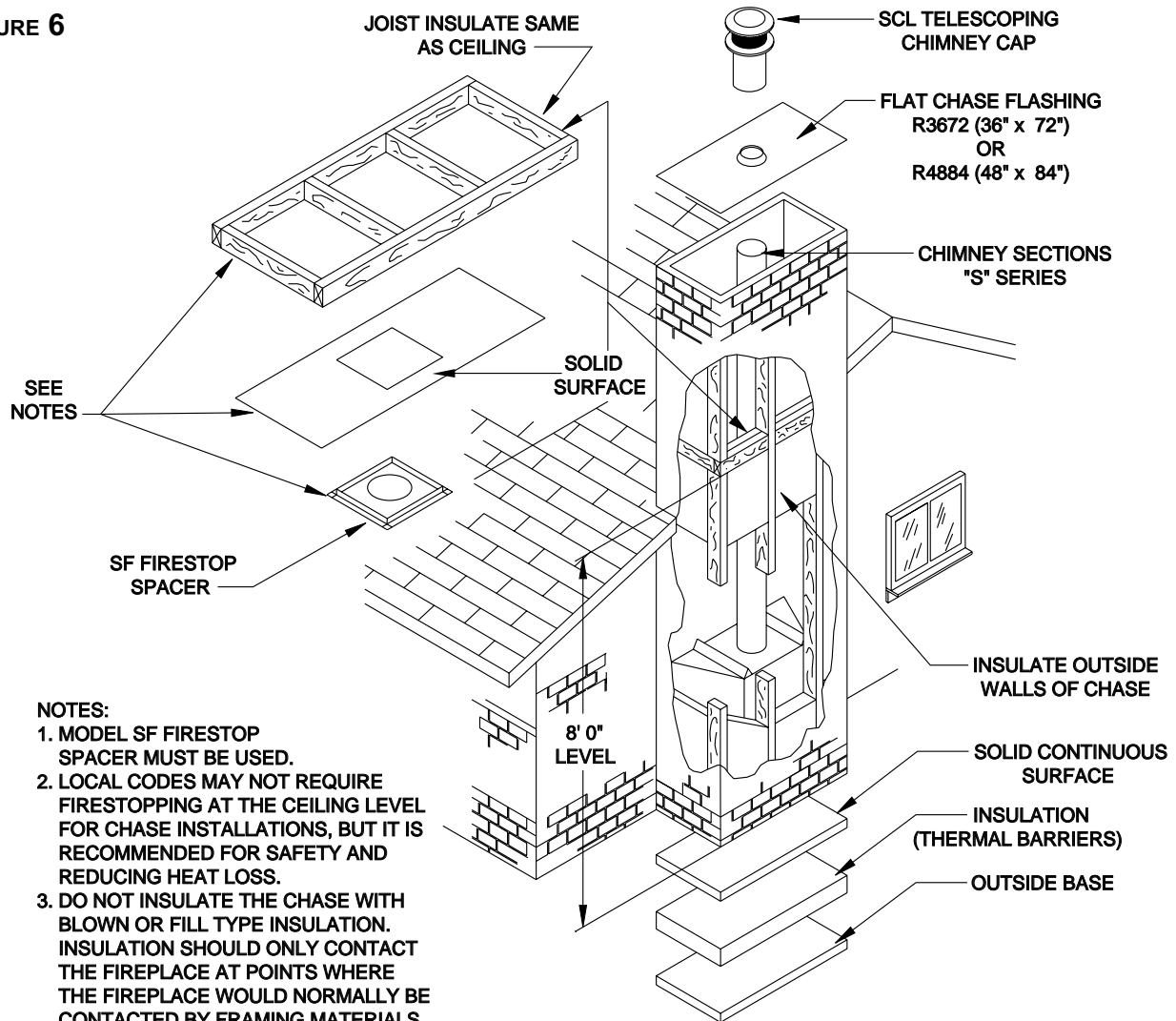

INSTALLATION PREPARATION

FIGURE 7

SINGLE STORY INSTALLATION WITH ATTIC SPACE

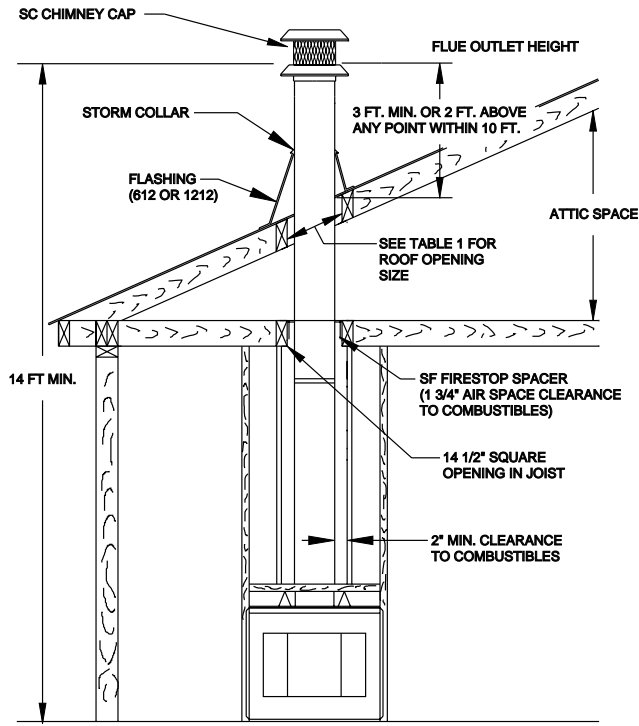

FIGURE 8

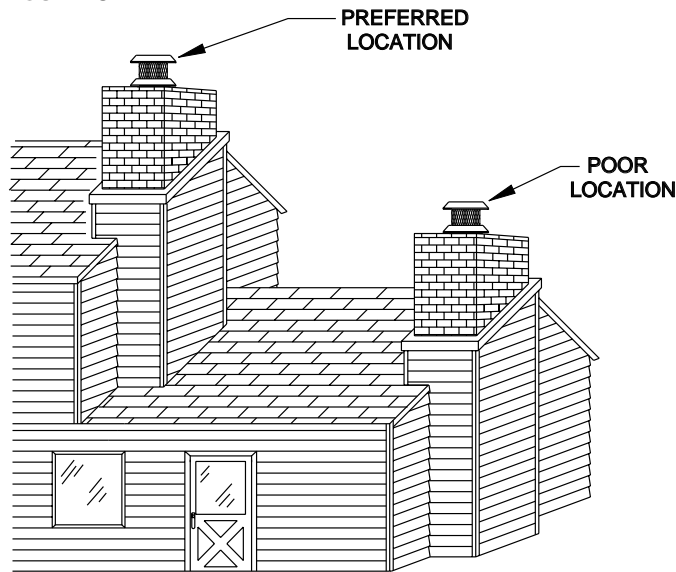
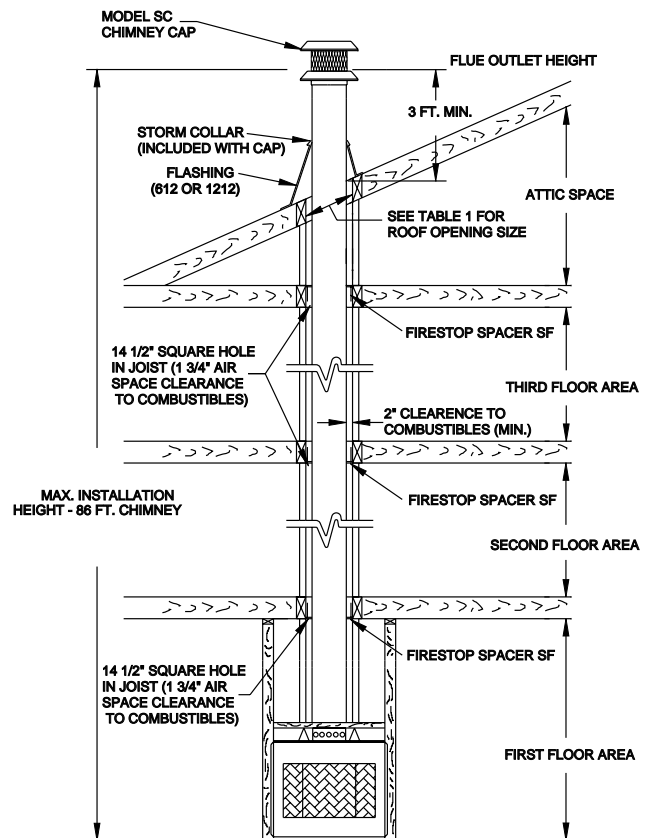

FIGURE 9

MULTIPLE STORY INSTALLATION



FLOOR PROTECTION

If this fireplace is installed on a combustible floor, the floor area 20 inches in front of, and 12 inches either side of the fireplace opening must be protected by an insulating noncombustible hearth extension. This hearth extension may be either minimum 6-inch thick stone or brick as shown by Figure 10, an H2066 Hearth Extension Kit or a locally constructed hearth equivalent to the H2066.

The insulation used in the H2066 hearth extension has a thermal conductivity (K Factor) of .43. If you do construct a hearth extension equivalent to the H2066, be sure the insulation you use has enough compressive strength to support the weight of the covering materials and persons standing on it, and insulating qualities equal to or better than the 2" covering provided by the H2066.

FIGURE 10

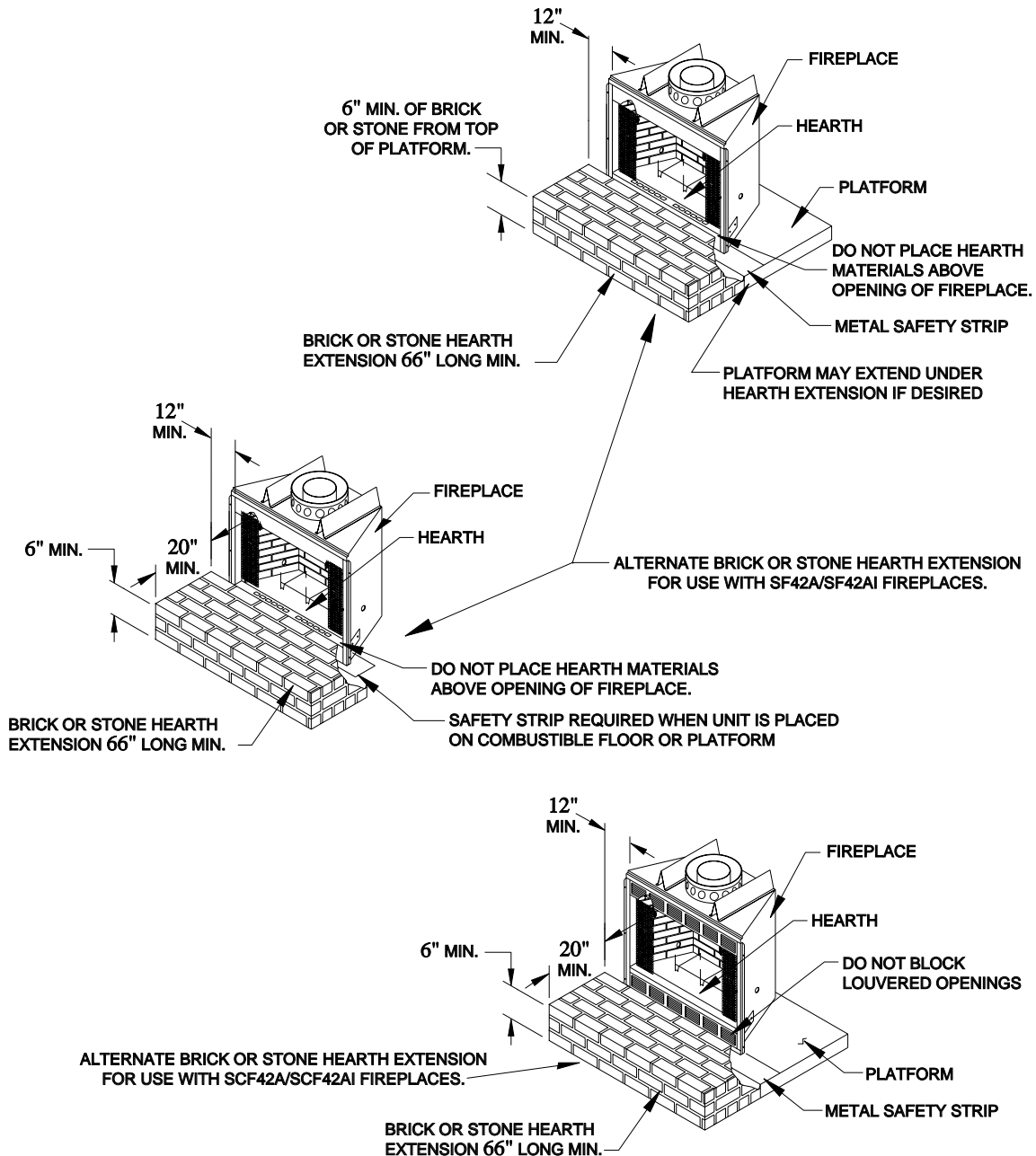

FLOOR PROTECTION

The ability of insulating material to retard the transfer of heat may be expressed as either Thermal Conductance (C), Thermal Conductivity (K), or Thermal Resistance (R). The mathematical relationship of these values and the formulas for converting one value to another is as follows:

- C = K divided by the material thickness
(Example C = .43 divided by 1/2 (.50)
C = .86)
- K = C multiplies by the material thickness
(Example K = .86 multiplied by 1/2 (.50)
K = .43)
- R = The material thickness divided by K
(Example R = 1/2 (.50) divided by .43
R = 1.16)

FIGURE 11

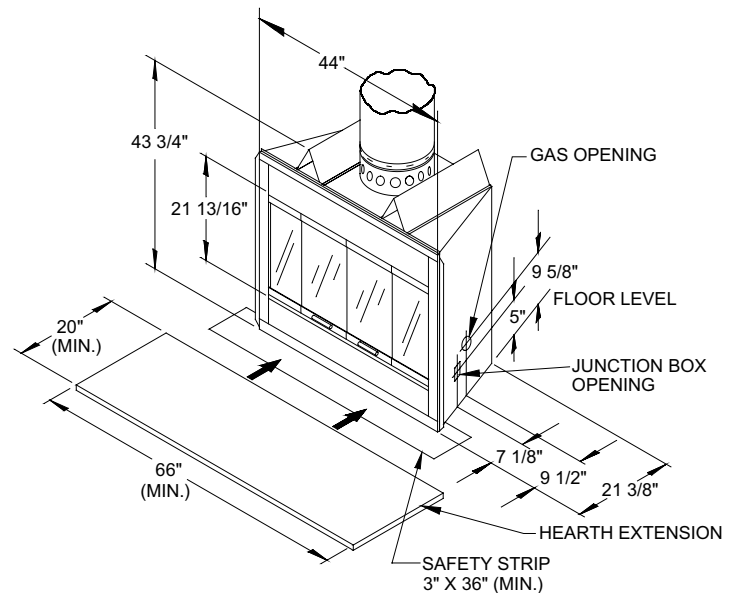
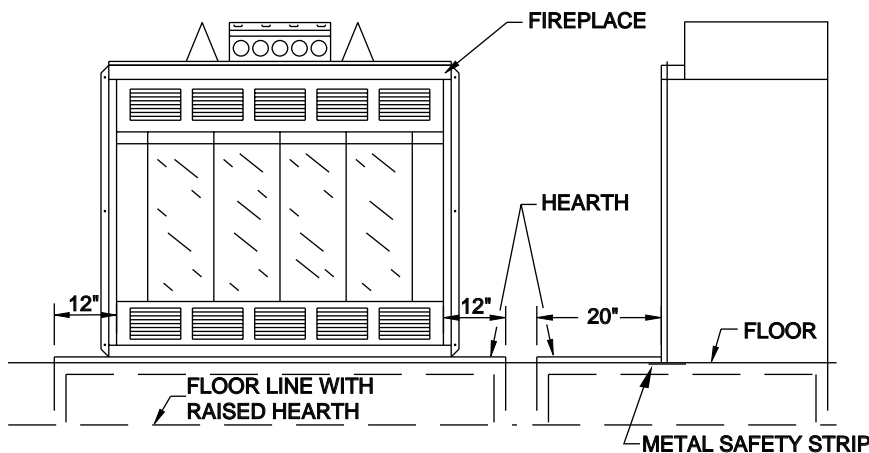

FIGURE 12



WARNING:
THE HEARTH EXTENSION AND THE GALVANIZED METAL STRIP SHOULD BE INSTALLED ONLY IN A HORIZONTAL RELATIONSHIP TO THE FIREPLACE, AS ILLUSTRATED.

With either type hearth extension minor shifting of the supporting floor or expansion and contraction may eventually cause a crack to develop between the hearth extension and the face of the fireplace. To help prevent the crack from developing, the hearth extension materials must be firmly fastened in place. Wall ties should be screwed to the face of the fireplace and imbedded in the mortar joints of brick, stone, or other non-combustible materials. The metal safety strip packed with the fireplace must be placed beneath the fireplace and extended under the hearth extension or into a mortar joint of the hearth extension as shown by Figures 10, 11, and 12. In the event a crack does eventually develop, the metal safety strip will serve as a barrier to prevent sparks or embers from falling from the fireplace onto combustible flooring materials.

The hearth extension must not block the side air vents, or air inlet louvers on the lower front of the fireplace. These openings must be unobstructed to assure an adequate flow of cooling air around the firebox. If the fireplace is equipped with a blower, or may be equipped with one at a later date, the hearth extension must not prevent the removal of the lower louver panel for servicing the blower. Plan adequately by determining the finished height of the hearth extension to be used and elevate the fireplace on a platform, if necessary, to prevent obstructing the air openings or lower louvered panel.

FIREPLACE COMPONENTS

FIGURE 13

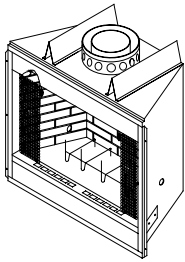

SF42A/SF42AI

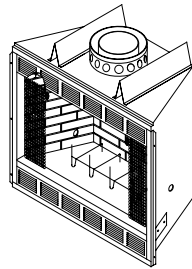

SCF42A/SCF42AI

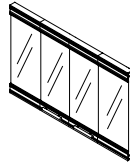

GD42B OR GD42PB
GLASS DOOR KIT

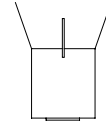

SCS
CHIMNEY
SUPPORT

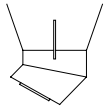

SE30 30°
ELBOW

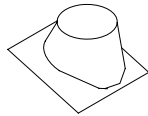

612-1212
FLASHING

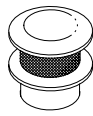

SC ROUND
CHIMNEY CAP

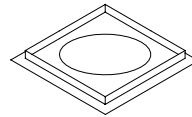

SF FIRESTOP
SPACER

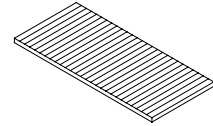

H2066 HEARTH
EXTENSION KIT



403 DUCT
CONNECTOR

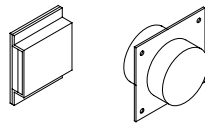

AK4 COMBUSTION
AIR ASSEMBLY

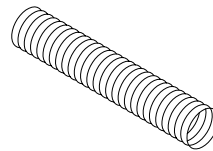

FP-4-U
UNINSULATED
FLEX PIPE

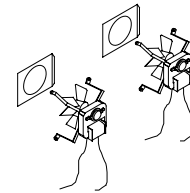

FA2 FAN
ASSEMBLY

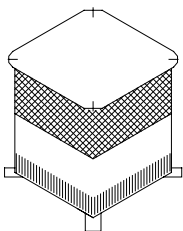

CF8
CHIMNEY CAP
Must use with VFK



S48



S36

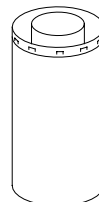

S18

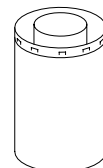

S12

FIREPLACE COMPONENTS

MODEL	DESCRIPTION
SF42A	42-inch non-circulating fireplace
SF42AI	42-inch insulated non-circulating fireplace with insulating outer wraps.
SCF42A	42-inch circulating fireplace
SCF42AI	42-inch insulated circulating fireplace with insulating outer wraps.
S48	4-foot chimney section (8-inch diameter flue)
S36	3-foot chimney section (8-inch diameter flue)
S18	18-inch chimney section (8-inch diameter flue)
S12	1-foot chimney section (8-inch diameter flue)
SE30	30-degree elbows (package contains two 8-inch diameter elbows.)
SCS	Chimney support (required when chimney height exceeds 30 feet)
SC	Round chimney cap for contemporary installation, includes storm collar
SCL	Round telescoping chimney cap
SQL8	Square telescoping chimney cap (18 1/2" x 18 1/2")
612	0-6/12 pitch flashing for contemporary installation. One required with SC round chimney cap on 0-6/12 pitch roof.
1212	6/12-12/12 pitch flashing for contemporary installation. One required with SC round chimney cap on 6/12-12/12 pitch roof.
SF	14-1/2-inch firestop spacer - One required at each ceiling or floor level
SF-30	Firestop spacer - 30" chimney incline through ceiling or floor
FP-4-U	4-inch uninsulated combustion air duct - 8-foot length
403	4-inch duct connector (for splicing FP-4-U ducts, includes one connector and two clamps)
AK4	4-inch outside combustion air assembly
GD42PB	Optional 42-inch polished brass glass door kit
GD42B	Optional 42-inch black finish glass door kit
FA2	Optional fan assembly - includes switch. Installs under fireplace by removing lower grille panel of fireplace. (SCF42A & SCF42AI)
H2066	Hearth extension - protects floor against sparks and radiant heat (Residential installation) 20" x 66"
JB1	Junction box - For Optional Blower Assembly Installation. Must be installed at the time of fireplace installation if the model FA2 Fan is to be installed.
S8	Telescope assembly for use with telescoping chimney caps.
CF8	Terra cotta chimney cap (Must use with VFK)

FIREPLACE INSTALLATION

LOCATION SELECTION

Unpack and check the fireplace and chimney for damage. If any items have been damaged, report this to your dealer. Before beginning the installation, be sure you have the proper parts in sufficient quantity. Refer to the Parts Diagram and List section of this manual for proper identification of parts.

Do not substitute parts. Use only parts listed for use with Monessen Hearth Systems Models BWB500, BWB500I, BWBC500, and BWBC500I fireplaces.

FIREPLACE INSTALLATION

1. Refer to Figure 1 for an example of a typical installation of the fireplace components.
2. Be sure the location of the fireplace will provide the required clearances indicated by Figures 1, 2, 4, & 5 and the minimum chimney air space clearance to combustibles of two inches.
3. Set the fireplace in the desired location and be sure it is securely supported and leveled. Check the face of the fireplace with a carpenter's level and if it is not plumb; correct it by placing shims under the edges of the fireplace.
4. Block in the fireplace to prevent any shifting of the firebox. Secure the fireplace with nails or screws through the flanges located on each side of the fireplace. Do not enclose the fireplace until the combustion air duct and chimney pipes are installed.

NOTE: Some local codes may require electrically grounding the fireplace and chimney.

CHIMNEY INSTALLATION

In order to assure safe and satisfactory performance of the fireplace, it is very important to properly install the chimney. This is an important part of the installation and the sections of this manual pertaining to chimney installation should be reviewed very thoroughly.

For your safety, some of the important things to remember in regard to chimneys are listed below:

1. Use only parts and accessories labeled for use with this fireplace.
2. Use only undamaged parts and accessories.
3. Enclose the chimney where it passes through the living spaces to prevent contact with and possible damage to the chimney.
4. Install firestop spacers at each ceiling level.
5. Install the proper chimney cap or chimney housing on the chimney to prevent the entry of rain and debris into the chimney and to assure the proper venting of smoke.
6. Do not use more than four elbows in the chimney.

NOTE: To select the proper chimney height, refer to Figures 1, 7, 9, and 14. The flue outlet must be a minimum of three feet above the highest point where the chimney penetrates the roof and a minimum of two feet above all portions of the building within ten feet. If the chimney is to include elbows to offset the chimney, refer to the Chimney Offset and Cap Installation section of this manual. There must be at least two inches air space between all sections of the chimney and combustible materials between floors.

CHIMNEY INSTALLATION

FIGURE 14

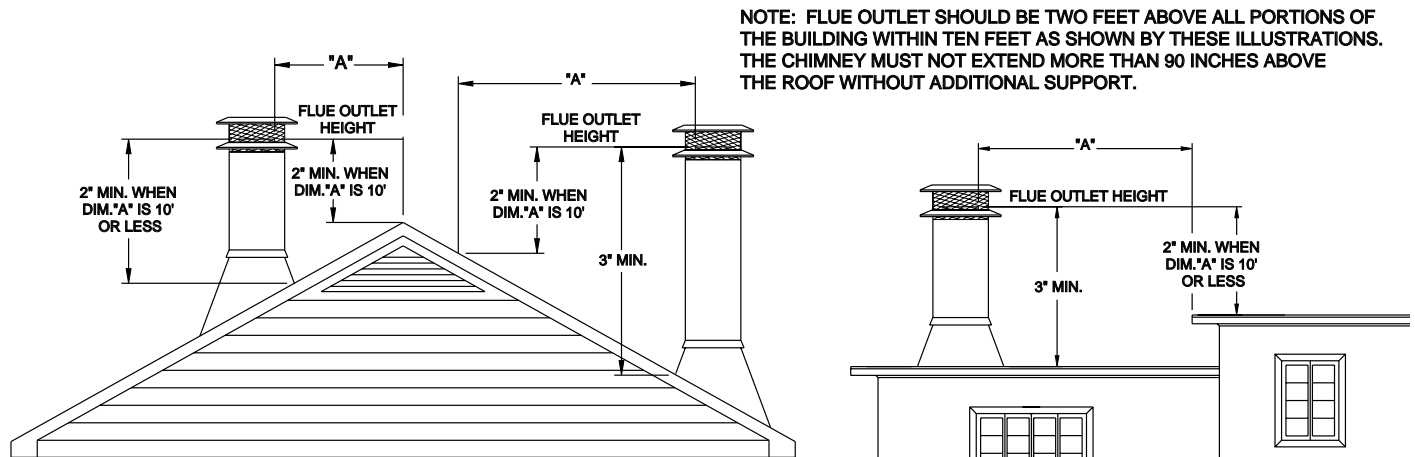

1. Lay out, cut and frame openings through all ceilings and the roof at the point where the chimney will pass through. Unless the chimney is to be offset, the point where the center line of the chimney will pass through the ceiling and roof can be determined with a plumb line as shown by Figure 15. The fireplace should be located in the planned installation position. After the center line is established and a nail is driven to mark the point, the opening can be cut if you are satisfied with the chimney location relative to ceiling and roof joists and/or any other obstructions. The roof opening center line should be marked by driving a nail through the roof from underneath that will penetrate the roof and can be located from the rooftop. If the chimney is to penetrate a pitched roof, the hole in the roof must be rectangular instead of square and should be sized according to Table 1.
2. Install the firestop spacer as required from beneath the ceiling unless the space above is attic space. In an attic, the firestop spacer should be installed at the floor level of the attic. Figure 17. You must have joists or headers on all four sides of the spacer and use a minimum of four 8-penny nails to secure the spacer.
3. To install the “S” series chimney sections, insert the male end of the flue, the smallest diameter pipe, into the flue outlet of the fireplace and press down until the snap locks engage. Continue the process, adding the chimney sections on top of each other until the chimney is at least six inches above the roof opening on all sides. As the chimney sections are installed, check each joint to make sure it is properly locked to the previous section. If additional strength of the outer pipe joints is desired, you may use two or three sheet metal screws placed through the area where the outer pipes overlap one another. To install these screws, drill a 1/8-inch diameter hole through the chimney sections, taking care not to penetrate the inner flue pipe. Warning: Be very careful when drilling the holes into the outer pipe. The drill must not penetrate the inner stainless steel pipe.

NOTE: If you intend to have a total fireplace installation of more than 30 feet you must use chimney support model SCS at or below 30 feet to support the weight of additional chimney pipe.

To install the chimney support, place the crimped end of the flue and outlet air duct portions into the last section of chimney pipe. Push down until the outside or inlet air duct of the chimney support overlaps and snap locks the chimney support into the chimney section.

Nail the support straps tightly to a building frame member or ceiling joist as shown by Figure 16. You must use at least two 8-penny nails per strap.

CHIMNEY INSTALLATION

FIGURE 15

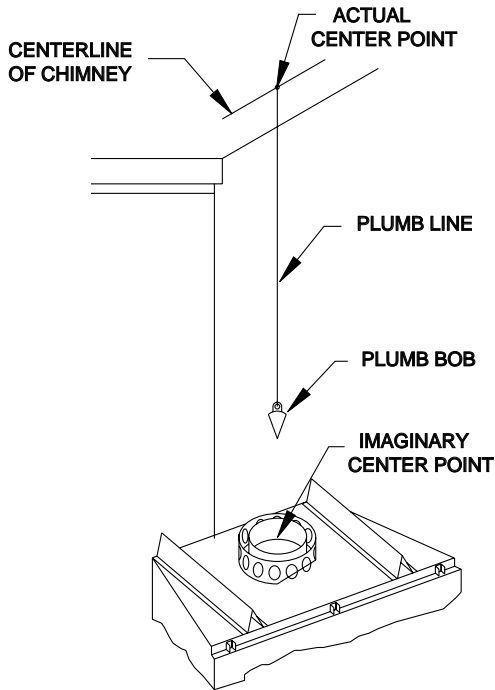
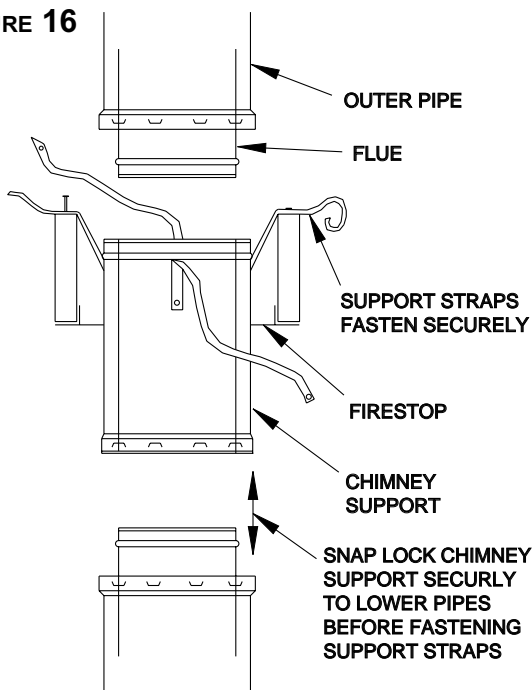

TABLE 1

ROOF PITCH	MINIMUM REQUIRED ROOF OPENING MINIMUM FRAMED OPENING	
	"S" SERIES DOUBLE WALL CHIMNEY	"E" SERIES DOUBLE WALL CHIMNEY
0/12	14 1/2" x 14 1/2"	17" x 17"
1/12	14 1/2" x 14 5/8"	17" x 17" 1/8"
2/12	14 1/2" x 14 3/4"	17" x 17" 1/4"
3/12	14 1/2" x 15"	17" x 17" 1/2"
4/12	14 1/2" x 15 1/4"	17" x 17" 3/4"
5/12	14 1/2" x 15 3/4"	17" x 18" 1/4"
6/12	14 1/2" x 16 1/4"	17" x 18" 3/4"
7/12	14 1/2" x 16 7/8"	17" x 19" 3/8"
8/12	14 1/2" x 17 1/2"	17" x 20"
9/12	14 1/2" x 18 1/8"	17" x 20" 5/8"
10/12	14 1/2" x 18 7/8"	17" x 21" 3/8"
11/12	14 1/2" x 19 3/4"	17" x 22" 1/4"
12/12	14 1/2" x 20 1/2"	17" x 23"

FIGURE 16



INSTALLATION OF FIRESTOP-SPACER AT ATTIC LEVEL

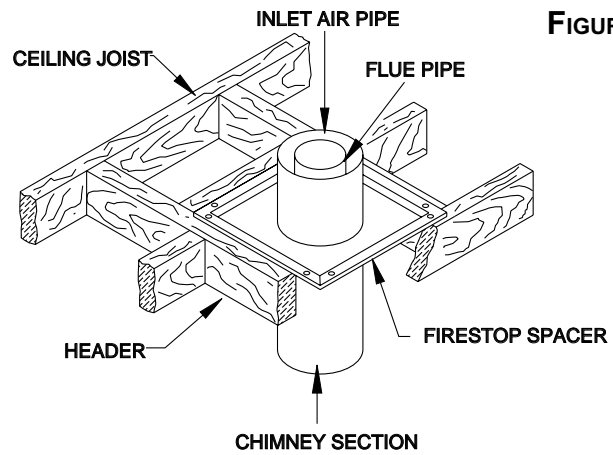
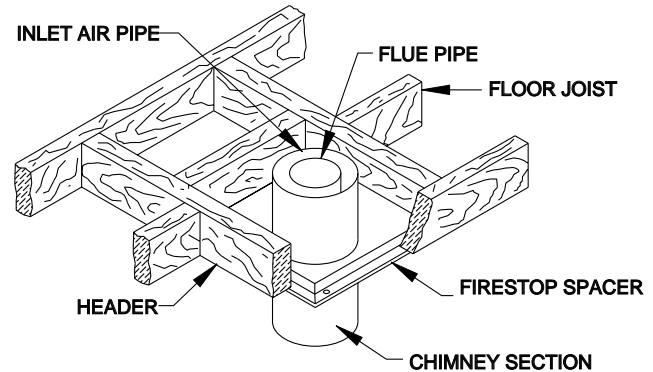

FIGURE 17

INSTALLATION OF FIRESTOP-SPACER AT FLOOR LEVELS



CHIMNEY OFFSET INSTALLATION

ELBOW INSTALLATION

The following are important points that should be observed when installing elbows on the fireplace:

1. The support straps of all elbows not installed directly on top of the fireplace should be nailed securely to the surrounding structure. This allows the support strap to carry the weight of the chimney above the elbow and prevents this weight from breaking the elbow or chimney sections apart. Figure 18.
2. Elbows should not be used in any combination that inclines the chimney more than 30 degrees from vertical.

NOTE:
ALTHOUGH BOTH HALVES OF THE ELBOW SET MAY HAVE TIE STRAPS, ONLY THE TOP HALF MUST BE SECURED. THE BOTTOM ELBOW HALF IS NOT REQUIRED TO BE SECURED FOR ADDED STABILIZATION OF PIPE

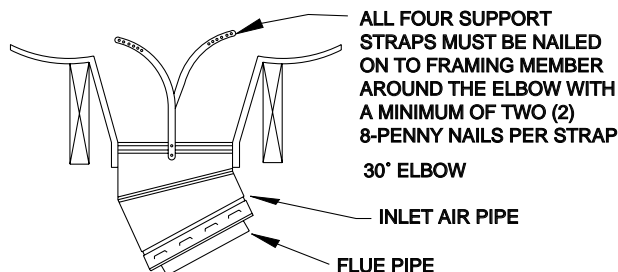

FIGURE 18

3. The limitations on the quantity of elbows per chimney are as follows: If the total height of the fireplace and chimney is — 14' 0" or more — two elbows may be used in the chimney. 21' 0" or more — four elbows may be used in the chimney.
4. The inclined portions of chimneys that pass through living spaces likely to be used for storage should be enclosed to avoid contact with and possible damage to the chimney. The minimum air space of two inches between the chimney and enclosing materials must be maintained. Figures 20 and 21 illustrates elbow installations.
5. The length of the inclined portion of chimney between elbows must not exceed 6 feet when unsupported or 20 feet if the chimney is supported at six-foot intervals with support such as metal support straps.
6. When enclosing the elbows and inclined portions of the chimney, enclosing materials must be installed vertically to maintain the required two-inch minimum air space clearance to the chimney at the extremities of the offset. It is recommended that enclosing material not follow the inclined portions of the chimney.

OFFSET INSTALLATION SEQUENCE

1. Determine the location and amount of offset required, then select the combinations of chimney sections and elbows required from the offset chart. Refer to Table 2.
2. Install the first SE30 elbow by placing the extended flue into the mating part of the fireplace or chimney section. Push down until the outside or inlet air duct of the elbow overlaps and the snaps lock the elbow into the fireplace or chimney section.
3. Nail the support straps to the framing member with a minimum of two 8-penny nails per strap.
4. Install the sections of pipe between elbows until the proper number of chimney sections have been installed.
5. Install the second elbow to return the run of the chimney to vertical.
6. Nail the support straps of the second elbow to a building frame member.
7. Continue installing the vertical portion of the chimney.

NOTE: If the inclined portion of the chimney passes through a floor or ceiling, an SF firestop spacer should be installed to provide the firestop and support required. Be sure proper spacing is maintained between the chimney and combustibles. Figure 19.

CHIMNEY OFFSET AND CAP INSTALLATION

FIGURE 19

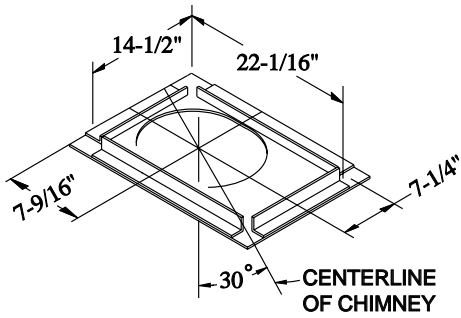

SF30 FIRESTOP SPACER

FIGURE 20

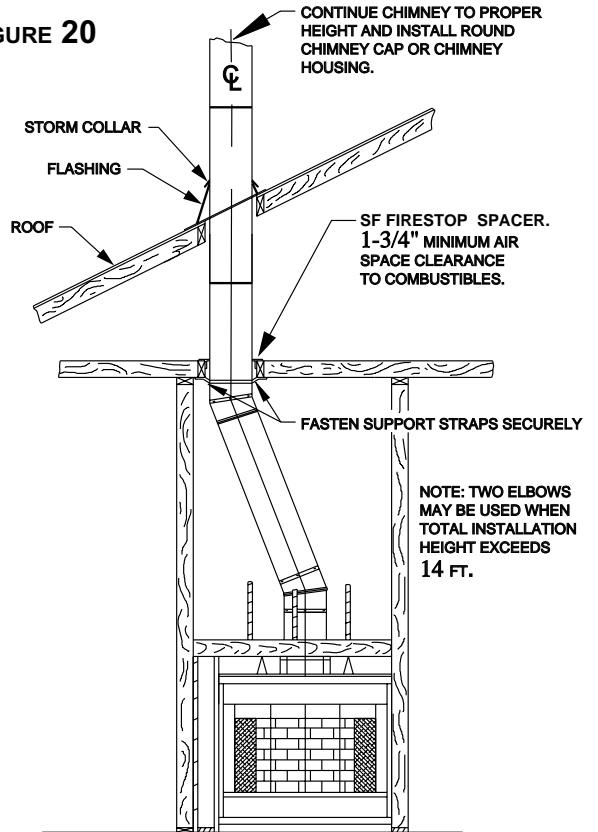

FIGURE 21

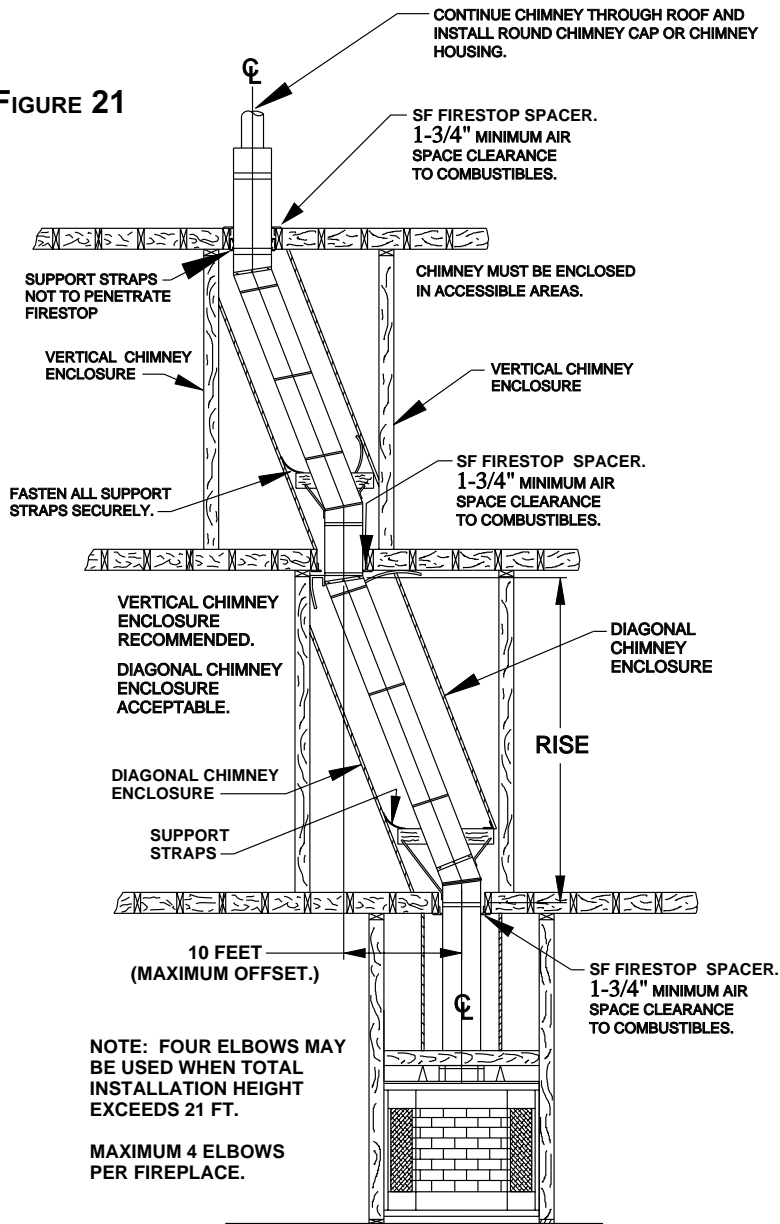
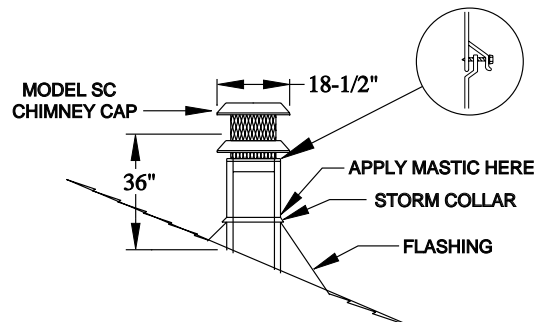
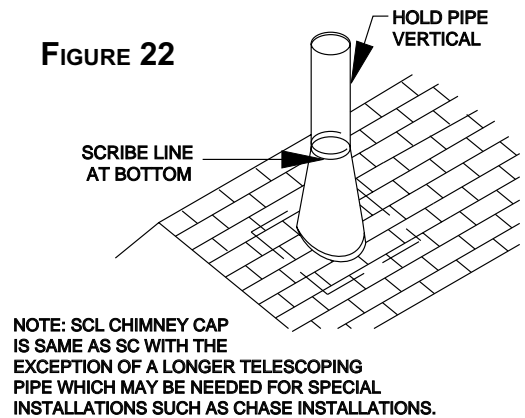

FIGURE 22



CHIMNEY CAP INSTALLATION

MODEL SC CHIMNEY CAP

SPECIAL NOTE: The proper height as previously explained is important to assure proper draft and safety. The chimney cap extends the flue outlet four inches above the top of the last section of chimney. This should be kept in mind when determining the proper height for the chimney. The chimney should not be extended more than 90 inches above the supporting roof structure without additional support. In the case of an “A” frame type construction or other steep pitch roofs that require more than 90 inches of chimney above the roof, a support should be attached to the chimney at the 90 inch level that is strong enough to support a wind load of 3-1/8 pounds for each inch the chimney extends above 90 inches. The flue outlet must be a minimum of three feet above the point where it penetrates the roof. Figure 14.

CAUTION: Be careful to avoid electrical shock hazard when contacting wires to the metal chimney components.

1. Extend the regular chimney sections until the top of the chimney is 4 inches below the total flue height desired. Do not snap the last section of inlet air duct or largest diameter pipe in place until Step 3 is completed.
2. Remove the shingles from around the chimney so that the flashing may be installed, with the upper part of the flashing under the shingles.
3. Set the flashing on the roof and scribe a line around the flashing, then cut the top off the flashing by cutting 1/4 inch below the scribed line. This should increase the diameter of the flashing outlet sufficiently to allow the flashing to be placed over the chimney. See Figure 22.
4. Snap the last section of inlet air duct in place and slide the flashing over the chimney. Adjust the chimney to assure that the proper minimum clearances are maintained.
5. Nail the flashing securely in place with eight nails.
6. Seal the crack between the top of the flashing and the chimney with mastic. Leave some excess mastic at this area to be used in step eight. **NOTE:** Use pliers and wear gloves when performing step seven to minimize the danger of cutting your hands on the edge of the storm collar.
7. Place the storm collar around the chimney and put the collar together like a belt in belt loops. Slide the end of collar under the two loops on the other end with the loops facing up. Overlap the ends of the collar until it is tight against the chimney. Bend the free end of the collar back over the loops to hold the storm collar securely together. The excess end of the storm collar may be trimmed off.
8. Slide the storm collar down snugly against the flashing until the excess mastic left in step six is forced up into the crack between the storm collar and the chimney. This should make the joint between the flashing and the chimney watertight.
9. Install the chimney cap by placing the cap into matching parts of the last chimney section. Push down until the brackets on the bottom of the chimney cap sits on the chimney pipe. Then punch or drill 1/8 inch diameter holes in the inlet air duct (chimney pipe) where specified on the brackets and fasten it down with the No. 8 screws provided. Do not penetrate the inner stainless steel pipe while installing the screws.
10. Check all the parts of the fireplace, chimney and chimney termination cap to assure that no parts have been damaged or bent during installation and that all parts have been installed properly.

NOTE: The metal used for the chimney cap has a rust protective coating but the cut edges of the parts are not protected. To prevent rusting and rust staining of nearby structures, exposed parts of the chimney and chimney cap should be detergent washed and painted with a galvanized primer paint.

CHIMNEY HEIGHT AND OFFSET CHARTS

TABLE 2

STRAIGHT RUN
CHIMNEY SECTIONS

HEIGHT (INCHES)	INTERMEDIATE SECTIONS			
	12"	18"	36"	48"
35	0	0	1	0
39	2	1	0	0
47	0	0	0	1
52	0	1	1	0
58	1	0	0	1
64	0	1	0	1
70	0	0	2	0
75	1	1	0	1
82	0	0	1	1
87	0	1	2	0
94	0	0	0	2
99	0	1	1	1
105	0	0	3	0
111	0	1	0	2
117	0	0	2	1
122	0	1	3	0
129	0	0	1	2
134	0	1	2	1
141	0	0	0	3
146	0	1	1	2
152	0	0	3	1
158	0	1	0	3
164	0	0	2	2
169	0	1	3	1
176	0	0	1	3
181	0	1	2	2
188	0	0	0	4
193	0	1	1	3
199	0	0	3	2
205	0	1	0	4
211	0	0	2	3
216	0	1	3	2
223	0	0	1	4
228	0	1	2	3
235	0	0	0	5
240	0	1	1	4
246	0	0	3	3
252	0	1	0	5
258	0	0	2	4
263	0	1	3	3
270	0	0	1	5
275	0	1	2	4
282	0	0	0	6
287	0	1	1	5
293	0	0	3	4
293	1	0	0	6
305	0	0	2	5
310	0	1	3	4
317	0	0	1	6
322	0	1	2	5
329	0	0	0	7
334	0	1	1	6
340	0	0	3	5
346	0	1	0	7
352	0	0	2	6
357	0	1	3	5
364	0	0	1	7
369	0	1	2	6
376	0	0	0	8

CHIMNEY SECTIONS WITH ELBOW OFFSETS

ELBOW SET	CHIMNEY SECTIONS				TOTAL INCHES OFFSET	TOTAL INCHES RISE
	12"	18"	36"	48"		
1	0	0	0	0	4 1/2	17
1	1	0	0	0	10	26 1/2
1	0	1	0	0	13	31 3/4
1	2	0	0	0	15 1/2	36
1	1	1	0	0	18 1/2	41 1/4
1	0	0	1	0	22	47 1/4
1	2	1	0	0	24	50 3/4
1	0	0	0	1	28	57 3/4
1	0	1	1	0	30 1/2	62
1	1	0	0	1	33 1/2	67 3/4
1	0	1	0	1	36 1/2	72 1/2
1	0	0	2	0	39 1/2	77 1/2
1	1	1	0	1	42	82
1	0	0	1	1	45 1/2	88
1	0	1	2	0	48	92 1/4
1	0	0	0	2	51 1/2	98 1/2
1	0	1	1	1	54	102 3/4
1	0	0	3	0	57	107 3/4
1	0	1	0	2	60	113 1/4
1	0	0	2	1	63	118 1/4
1	0	1	3	0	65 1/2	122 1/2
1	0	0	1	2	69	128 3/4
1	0	1	2	1	71 1/2	133
1	0	0	0	3	75	139 1/4
1	0	1	1	2	77 1/2	143 1/2
1	0	0	3	1	80 1/2	148 1/2
1	0	1	0	3	83 1/2	154
1	0	0	2	2	86 1/2	159
1	0	1	3	1	89	163 1/4
1	0	0	1	3	92 1/2	169 1/2
1	0	1	2	2	95	173 3/4
1	0	0	0	4	98 1/2	180
1	0	1	1	3	101	184 1/4
1	0	0	3	2	104	189 1/4
1	0	1	0	4	107	194 3/4
1	0	0	2	3	110	199 3/4
1	0	1	3	2	112 1/2	204
1	0	0	1	4	116	210 1/4
1	0	1	2	3	118 1/2	214 1/2
1	0	0	0	5	122	220 3/4

CHIMNEY CAP CHASE INSTALLATION

The preinstalled chimney sections should be no more than 10 inches below the top of the chase. The installation should be planned so that either an 18-inch or 36-inch chimney section will be used for the top section. This is necessary to ensure complete engagement of the inlet air telescope and chimney cap into the top section.

CAUTION: Be careful around electrical wires to avoid the electrical shock hazard of contacting the wires with the metal chimney components.

NOTE: When two fireplace chimneys are terminated above the same chase, the centers of the chimney caps should be at least 24 inches apart to help prevent smoke from a fireplace in use from being drawn down the chimney of a fireplace that is not in use. Additional spacing between caps or staggering the height of the caps will further lessen the likelihood of this occurring.

1. Extend the chimney sections until the top of the chimney is not more than 10 inches below the top of the chase.
2. Center the hole in the chase cover over the chimney. The chase cover overhang should be lanced, formed over the chase and secured with nails. This prevents water from seeping under the chase cover. If two or more chase covers are to be used on the same chase, they should be soldered together to form two watertight seams.
3. Place the inlet air telescope inside the hole in the chase cover and lower it down into the mating pipe of the chimney until the flange on the telescope section rest on the flange of the chase cover. Note: All telescoping sections should extend a minimum of three inches inside the mating chimney pipes.
4. Install the SCL or SQL8 chimney cap by placing the cap into the matching duct telescope and flue telescope of the last chimney section as shown by Figure 23. Lower the cap until the brackets on the bottom of the chimney cap rests on the raised flange of the flat flashing, punch or drill 1/8 inch diameter holes in the raised flange of the flat flashing, and fasten the cap to the flashing with the No. 8 screws provided.
5. Check all parts of the chimney and chimney cap to assure that no parts have been damaged or bent during installation and that all parts have been installed properly.

NOTE: The metal used for the chimney and chimney cap has a rust-protective coating but the cut edges of the parts are not protected. To prevent rusting and rust staining of nearby structures, exposed parts of the chimney and chimney cap should be detergent-washed and painted with galvanized primer paint.

FIGURE 23

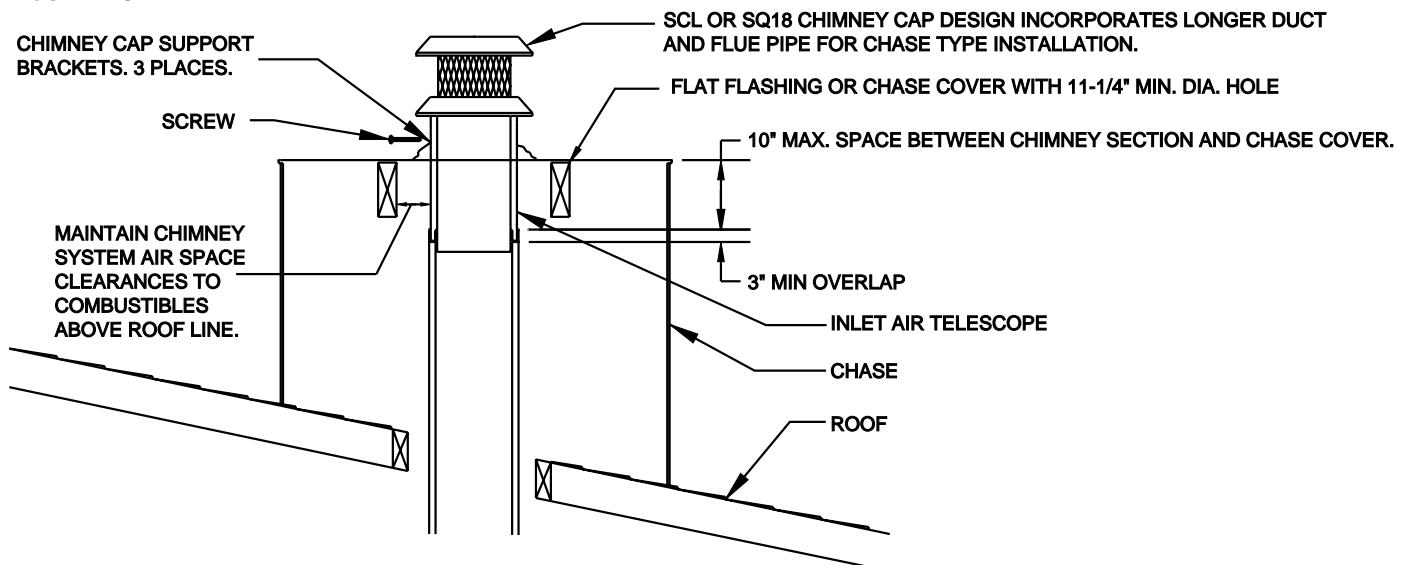

OUTSIDE COMBUSTION AIR PRECAUTIONS & RECOMMENDATIONS

NOTE: The use of outside air for combustion is optional unless required by building codes. It is only necessary to supply outside combustion air to one side of the fireplace. Use the model AK4 combustion air kit.

FIGURE 24 SECURING OUTSIDE AIR STARTING COLLAR TO FIREPLACE

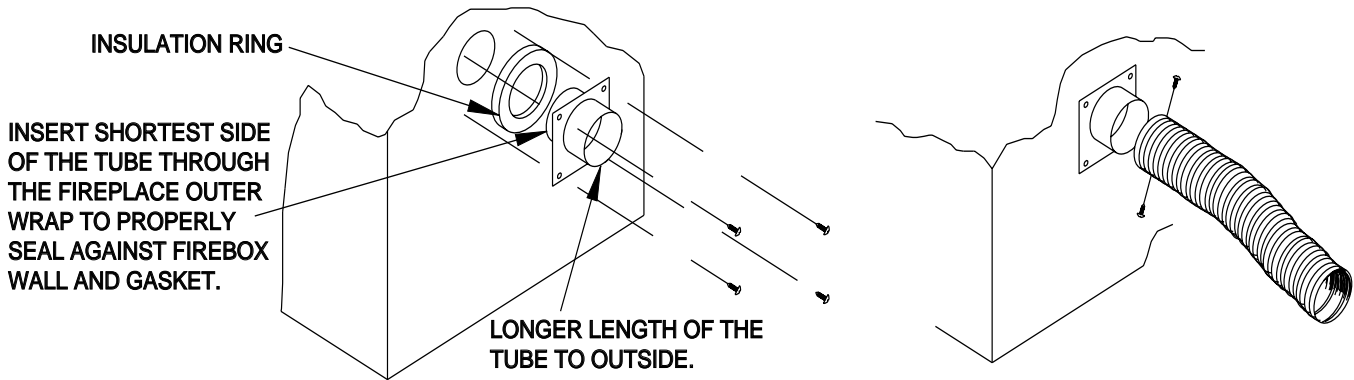

STEP 1: SECURE OUTSIDE AIR STARTING COLLAR TO LEFT SIDE OF FIREPLACE WITH FOUR SHEET METAL SCREWS PROVIDED.

STEP 2: SECURE OUTSIDE DUCT TO STARTING COLLAR WITH DUCT CLAMP OR SCREWS.

NOTE: THE STARTING COLLAR EXTENDS THROUGH THE OUTER FIREPLACE JACKET AND WILL SEAL AGAINST THE FIREBOX WALL WHEN SECURED AS INDICATED.

FIGURE 25

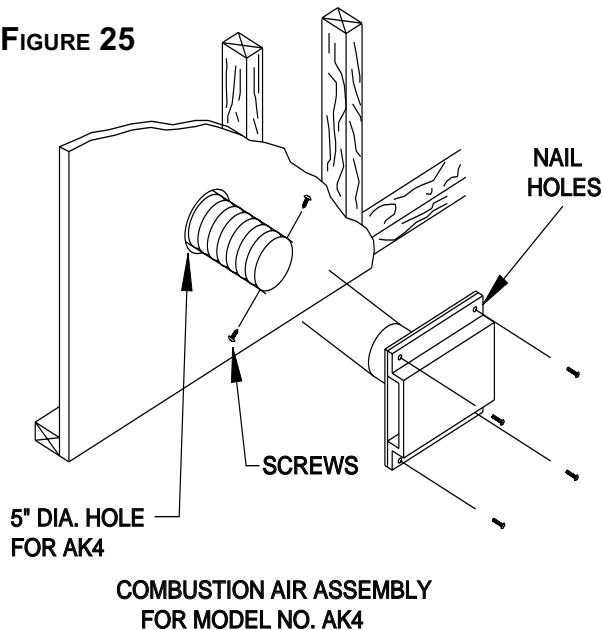
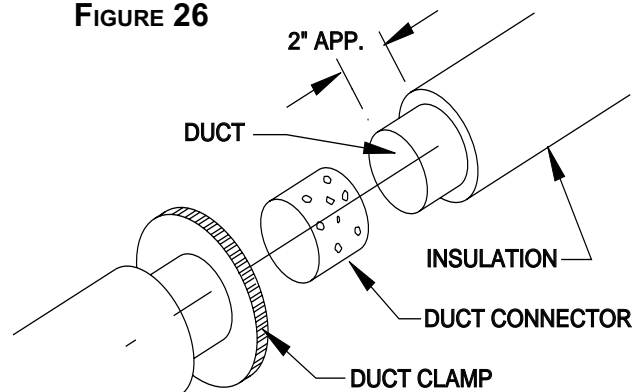

FIGURE 26



INSTALLATION OF THE MODEL 403 DUCT CONNECTOR

1. Push the insulation back approximately 2" from the end of each duct .
2. Slip each duct over the duct connector until an equal length of the connector extends into each duct.
3. Place a duct clamp over the end of each duct and tighten it down snugly.
4. Push the insulation back into place and over the duct clamp.

OUTSIDE COMBUSTION AIR PRECAUTIONS & RECOMMENDATIONS

OUTSIDE COMBUSTION AIR RECOMMENDATIONS (CONTINUED)

1. Extremely long runs and numerous turns in the duct leading from the fireplace to the combustion air assembly should be avoided. These conditions will increase the resistance to the free flow of air through the duct. Refer to Figures 1 and 27 for methods of installing the outside air for combustion assemblies.
2. The combustion air assembly should be located at an exterior location, which is not likely to be accidentally blocked in any manner. The assembly should be located above the snow line to prevent blockage by snow accumulation.
3. The combustion air inlet assembly should never be mounted in a garage or storage area where combustible fumes such as gasoline might be drawn into the fireplace.
4. Combustion air can be drawn from the crawl space under a house when an adequate supply of air is provided by open ventilation.
5. Do not take combustion air from attic space or garage space.

FIGURE 27

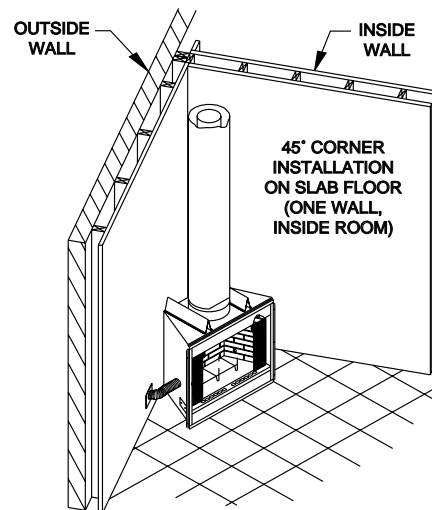
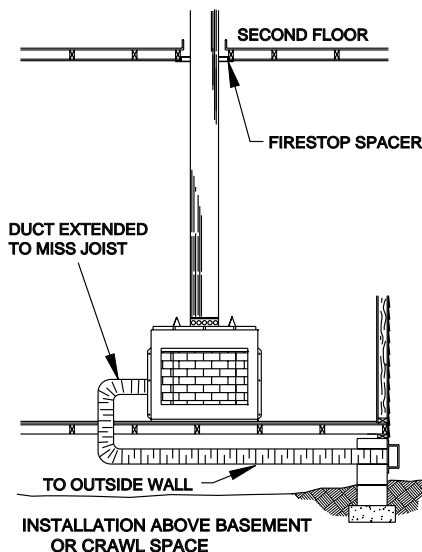
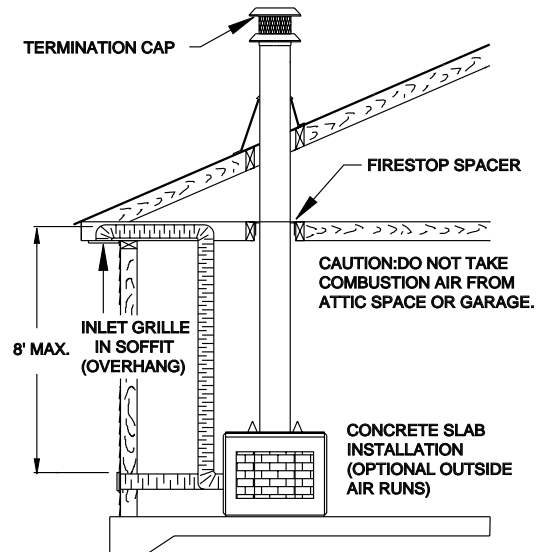
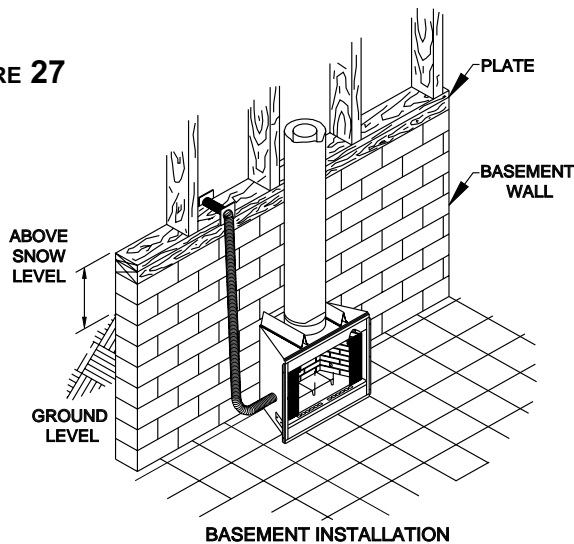

COMBUSTION AIR ASSEMBLY

MODEL AK4 COMBUSTION AIR ASSEMBLY

1. Remove the cover plate from the 4-inch outlet opening location on the left or right outside of the fireplace. DO NOT remove the cover if the outside air will not be connected.
2. Place the insulation ring between the AK4 starting collar and fireplace wall and place the starting collar (4 inch) into the hole on the side of the fireplace. Fasten it in place with the four sheet metal screws provided. Figure 24.
3. Cut a 5-inch diameter opening for model AK4 in the outside wall covering where the outside vent is to be located. Figure 25.
4. Select and cut a piece of duct sufficient length to attach to the fireplace and protrude at least three inches beyond the face of the wall to which the AK4 inlet air vent will be attached. The duct may be cut with a standard pocket knife (use FP-4 U duct for maximum efficiency and safety). Do not use a combustible duct. Always use UL Listed Class 0 or 1 duct material.
5. If the duct is the insulated type, push the insulation back from one end of the duct approximately two inches. Figure 26.
6. Slip the exposed end of the duct over the starting collar on the fireplace.
7. Using the sheet metal screws provided, secure the duct end to the collar attached to the fireplace.
8. Nail or screw the combustion air assembly to the surface of the wall.

NOTE: If the wall covering is brick or stone, use appropriate masonry fasteners. Mount the combustion air assembly with "TOP" upward to prevent cold air from entering through the wall. If it is necessary to splice the duct, a model 403 duct connector should be used to splice duct sections.

GAS APPLIANCE INSTALLATION

WARNING: Improper installation or operation of a gas appliance in this fireplace can allow unburned gas to leak out which will cause a fire or explosion hazard, or the release of poisonous carbon monoxide into the dwelling which can cause serious injury or death to its inhabitants. To reduce these risks to a minimum, the following important notices and instructions should be read and followed carefully.

IMPORTANT NOTICES:

1. The provision for a gas line is intended for connection to a decorative gas appliance which has an automatic shutoff device and complies with the Standard for Decorative Gas Appliances for Installation in Vented Fireplaces, ANSIZ21.60. If a decorative gas appliance is installed, it must be installed in accordance with the National Fuel Gas Code, ANSIZ223.1.

CAUTION: When a decorative gas appliance is installed, the fireplace damper must be set in the fully open position at all times.

CAUTION: If an unvented gas appliance is installed in the fireplace, the gas appliance must only be operated with the fireplace glass door fully open, if glass doors are installed on the fireplace.

WARNING: Do not operate an unvented gas log set in the fireplace with the chimney removed. The installer of the fireplace and gas appliance must describe the operation of the fireplace and appliance to the people who will be operating them and leave all instruction manuals with the operator of the appliance.

2. An approved gas shut off valve must be located outside the fireplace in an area accessible to the users of the fireplace.
3. All gas piping and fitting must be either steel or malleable iron. Unions must be of the ground joint type.
4. Some code authorities prohibit or place restrictions on the use of gas appliances in fireplaces. Check with local code authorities before proceeding with the installation.
5. The gas appliance and all connecting gas piping should only be installed by a licensed gas appliance installer. See Figure 28 for the gas line opening dimensions on the fireplace.
6. The installer should advise the persons who will use the appliance to set the fireplace damper in the full open position when the appliance is in use.

The following instructions only apply to passing the gas line through the fireplace wall. Follow the instructions provided by the appliance for the gas line, testing and adjusting it.

1. Locate the recessed area in the side refractory panel as shown by Figure 28.
2. Tap out a round hole in the brick liner with a hammer by tapping lightly on the recessed area.
3. Remove the two screws that hold the cover plates on the jacket wrap and discard the cover plate.
4. Use a screwdriver or similar tool to push the loose insulation out of the tube between the firebox and the outer jacket of the fireplace.
5. Install the gas pipe through the tube between the firebox and jacket.
6. Attach the gas appliance to the gas pipe according to the appliance maker's instructions.
7. Pack the insulation removed in step 4 around the pipe to prevent air flowing through the tube either into or out of the firebox.

GAS APPLIANCE INSTALLATION

8. Be sure the gas is turned off at the appliance, then turn the gas on at the cut off valve and test the gas line connections for leaks with soapy water solution or a liquid leak detector. **DO NOT USE A MATCH OR OTHER FLAME SOURCE TO CHECK FOR GAS LEAKS.** If a gas leak is detected, turn the gas off immediately and fix the leak.
9. Proceed with testing the appliance for leaks and adjusting it as required by the manufacturer instructions.

FIGURE 28

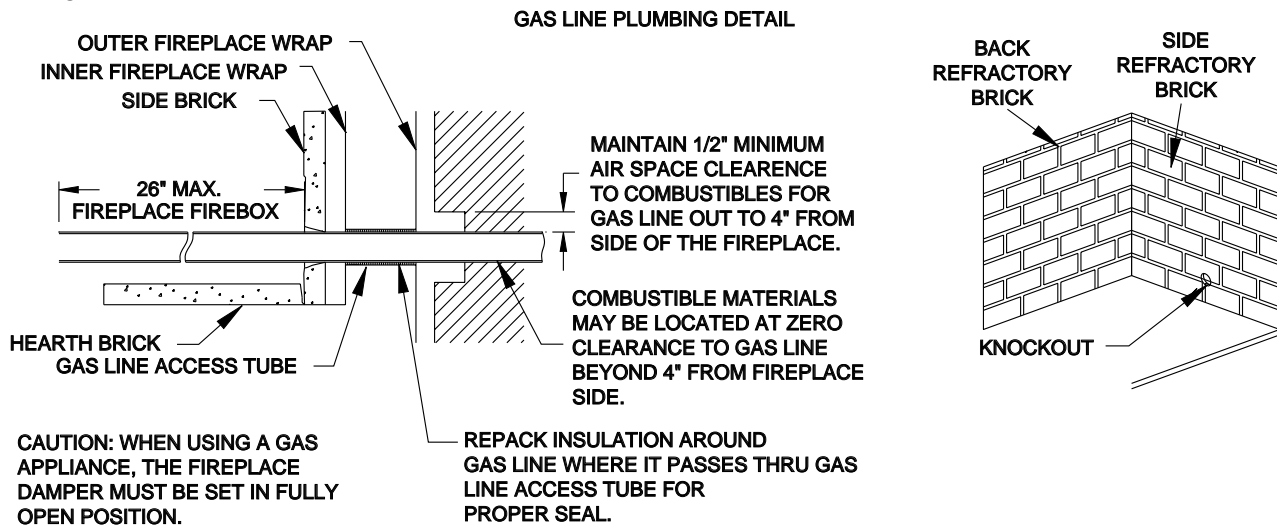

APPLYING DECORATIVE TRIM TO THE FIREPLACE

Do not allow the trim materials to extend closer than 3/8 inch to the vertical edges of the firebox opening if you plan to equip the fireplace with glass doors.

The face of your fireplace may be left exposed or trimmed with any noncombustible material such as brick, stone or marble. See Figure 29. If a trim is installed, be sure it is fastened snugly to the face of the fireplace. A crack between the material and the face of the fireplace could pose a fire hazard and impair the proper operation of the fireplace. Blocking the fireplace with framing and attaching the base to the supporting floor will further reduce the possibility of such a crack developing.

Wall ties should be fastened to the face of the fireplace with sheet metal screws and placed in the mortar joints of masonry trim.

Combustible material must not be installed below the top spacers of the fireplace or overlap the sides of the fireplace face. Figures 30 and 31. Seal the face of the fireplace to the surrounding wall with non-combustible caulk or trim materials to prevent cold air leakage around the fireplace.

The trim should not block or restrict in any way the flow of air into the side air inlets in the face of the fireplace.

Be sure to provide the required floor protection as described in a preceding section of this manual.

Combustible mantles and trim must be installed in accordance with the National Fire Protection Association - ANSI NFPA 211 Standard - Section 7-2.3.3.

TRIM INSTALLATION

INSTALLATION OF NON-COMBUSTIBLE FACING MATERIALS TO THE FRONT FACE OF THE FIREPLACE

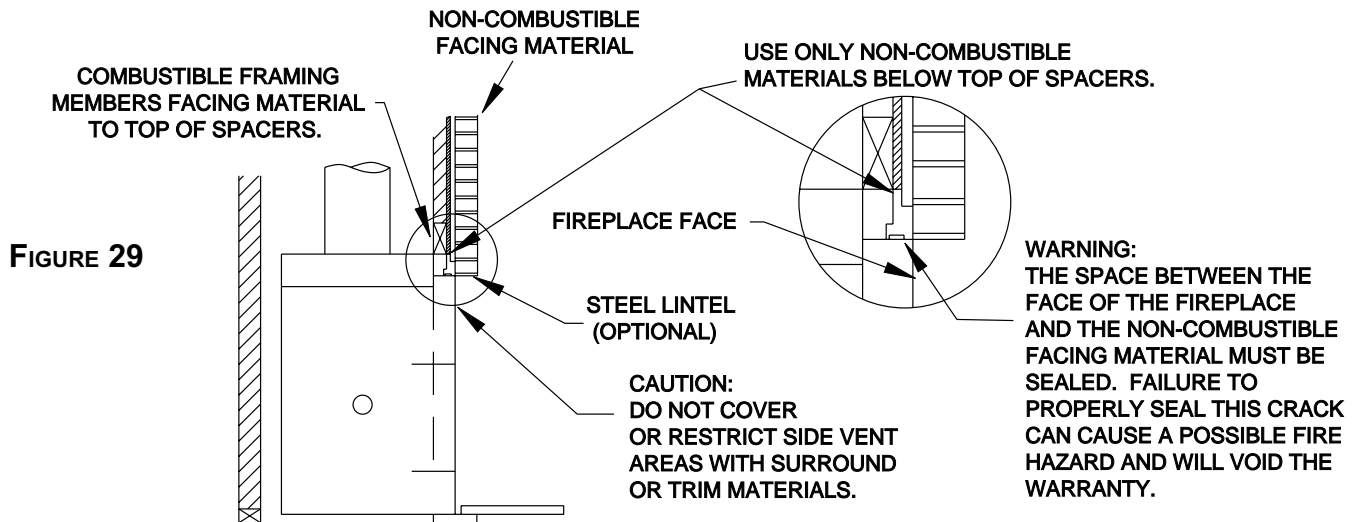

INSTALLATION OF COMBUSTIBLE DECORATIVE TRIM AND THE FIREPLACE SURROUND

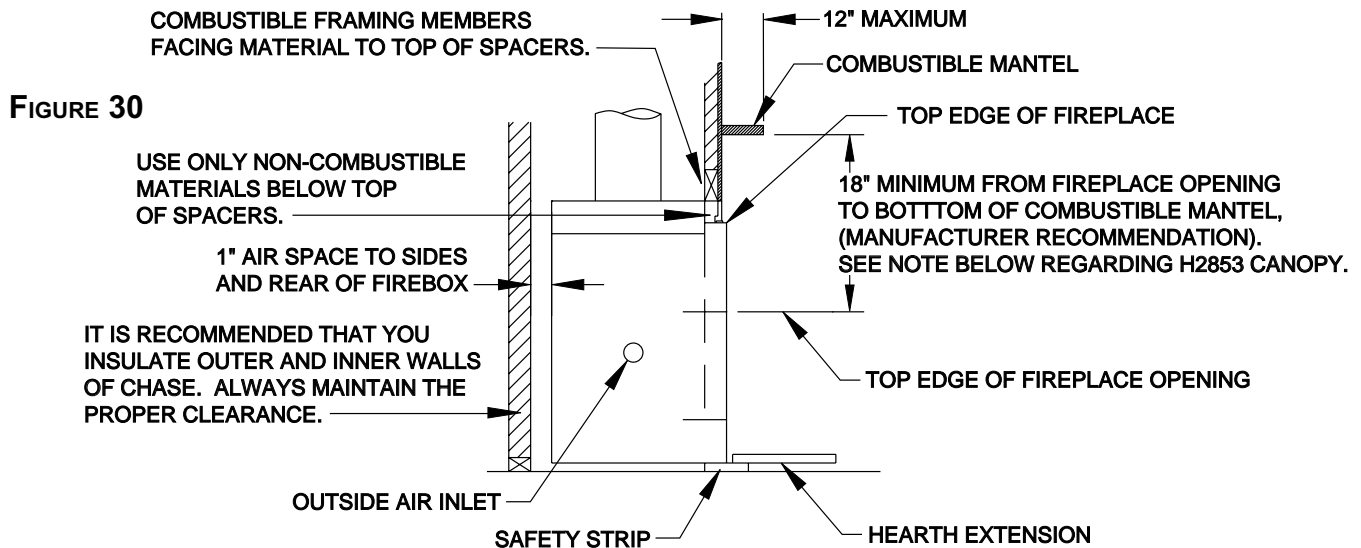

NOTE:
WHEN AN APPROVED ANSI Z21.11.2 UNVENTED ROOM HEATER IS INSTALLED IN THIS FIREPLACE, AN H2853 CANOPY MUST ALSO BE INSTALLED.

FIGURE 31

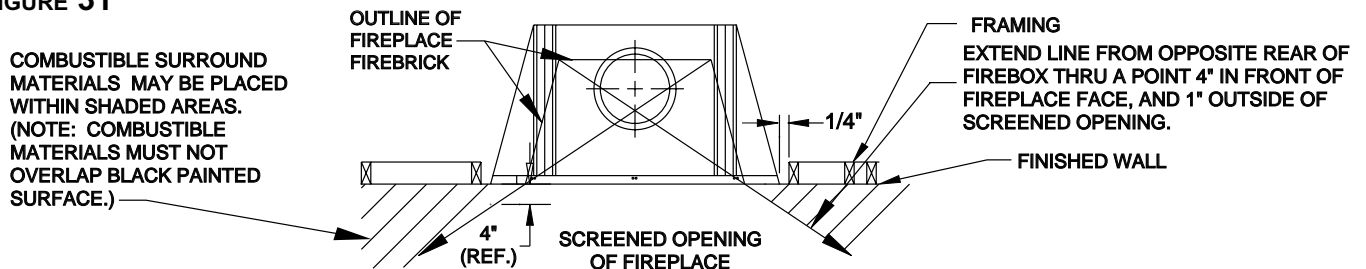

GLASS DOOR INSTALLATION AND FAN ACCESSORY

GLASS DOOR INSTALLATION

This fireplace has been tested and listed for use with optional Model GD42P or GD42PB glass doors. For installation of the Models GD42P or GD42PB glass doors, see the instructions provided with the doors.

FAN ASSEMBLY

The model BWBC500 and BWBC500I Fireplaces may be equipped with a accessory fan Model FA2. If the fireplace is to be equipped with this accessory at anytime, the JB1 junction box assembly must be installed on the fireplace as shown by Figures 32 and 33 during the installation of the fireplace. Unless the JB1 junction box is installed at this time, wall finishing materials must be removed to gain access to the side of the fireplace to install the JB1 junction box at a later date. Complete Installation and Operation Instructions for the FA2 Fan are included in the package with this accessory.

Note: A rectangular switch knockout is provided on the lower right hand face of the fireplace.

FIGURE 32

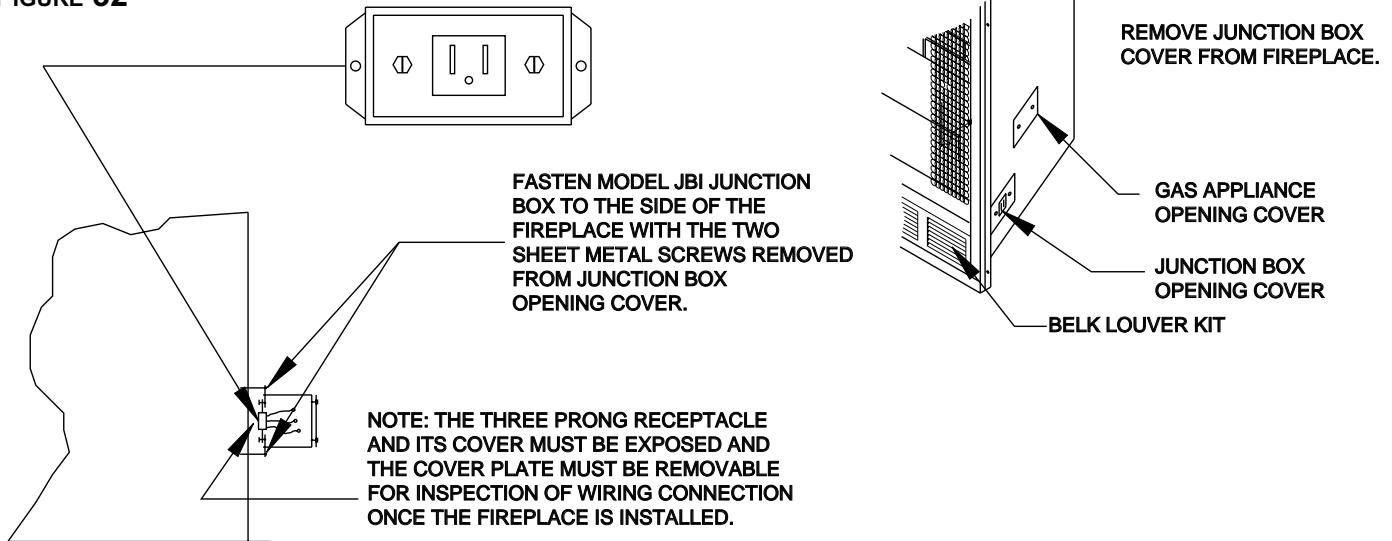
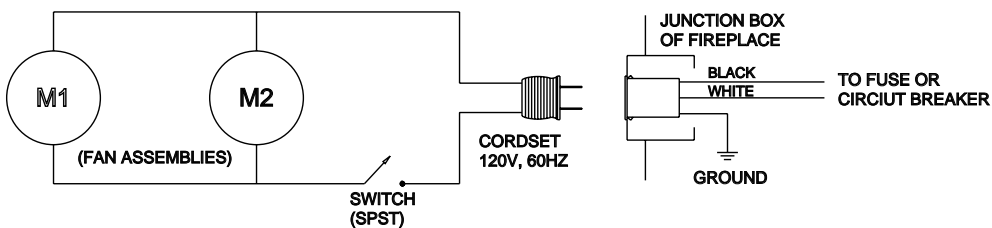

FIGURE 33



NOTE: THE JB1 JUNCTION BOX SHOULD BE INSTALLED AND THE RECEPTACLE WIRED TO THE ELECTRICAL SYSTEM OF THE STRUCTURE AT THE TIME OF INSTALLATION OF THE FIREPLACE OF THE FA2 FAN ASSEMBLY IS TO BE USED.

FIREPLACE OPERATION

WARNING: If a decorative gas appliance is used in the fireplace the fireplace damper must be fixed in an open position. (See additional operation information in section titled "Operation Guidelines".)

ADVANTAGES OF A WOOD BURNING FIREPLACE

These are the practical, ecological advantages of wood as a fuel. Also to be considered is the aesthetic appeal. Most of us consider a wood fire with nostalgia. We enjoy the aroma, and find the flickering light of a cozy hearth conducive to a happy remembrance of things past. Wood has a low ash content. And the little ash that remains after burning is useful in home gardening as a fertilizer and soil conditioner.

WHICH WOODS ARE BEST?

Each wood species offers something different in aroma or heat value, and you should consider your needs and desires before building your fire.

Softwoods, like pine, spruce, and fir are easy to ignite because they are resinous. However, a fire built entirely of softwoods burns out quickly and requires frequent replenishment. While a softwood fire is not too desirable for a long evening, it's fine in the morning when you want quick warmth, or late in the evening when you want a fire that will burn out before you go to bed.

On occasion when a longer fire is desired, it's best to combine softwoods with the heavier hardwoods such as ash, beech, birch, maple, oak and hickory. These hardwood species burn less rapidly, with shorter flames, and produce steady, glowing coals.

For the most pleasing aroma, you'll want to burn the wood of fruit trees such as apple and cherry, or nut trees such as beech, hickory and pecan. Such wood is generally more expensive, but a little combined with other wood, goes a long way. Start your fire with a mixture of softwood and hardwood, then add some fruit or nut wood for nostalgic aroma. Since most woods will not burn well when freshly cut, the wood you purchase should be reasonably dry. The sizes you buy are dictated by the size of your fireplace. Purchase logs that will fit when laid across your grate, and ask that the larger, heavier logs be split. Kindling should be short, easily split lengths of softwood, lumber yard or mill scraps, or twigs and branches gathered from your yard.

HOW TO BUILD A BETTER FIRE

The first three fires should be of moderate size to allow the fireplace to adjust and the bricks to cure before being subjected to larger fires.

First, make sure your room is well ventilated, your damper open and the flue is unobstructed. Then make sure your wood is dry and seasoned. Unseasoned wood burns poorly and coupled with poor ventilation or an obstructed chimney, leads to smoking problems.

If your fireplace is equipped with an outside combustion air assembly, open the combustion air inlet by pushing upward on the lever located above the firebrick on the left side of the firebox.

NEVER USE GASOLINE, GASOLINE-TYPE LANTERN FUEL, KEROSENE, CHARCOAL LIGHTER FLUID, OR SIMILAR LIQUIDS TO START OR "FRESHEN UP" A FIRE IN THIS FIREPLACE. KEEP ALL SUCH LIQUIDS WELL AWAY FROM THE FIREPLACE WHILE IT IS IN USE. USE OF THIS FUEL CAN CAUSE A SERIOUS EXPLOSION.

Prepare your fire by placing two logs on the iron grate or fire basket, and laying the tinder between them. Tinder may be dry scrap paper, twigs, or bark. On top place a small handful of twigs or split softwood kindling. Place more dry logs over this base. Keep logs close together, as narrow air spaces between them promote better drafts, and heat reflected between adjacent surfaces aids in raising and maintaining combustion temperatures.

FIREPLACE OPERATION

You'll need a minimum of three logs, preferably four, to make a good fire. Add kindling and new logs as needed to rekindle a dying fire. New logs should be added at the rear grate after raking the coals toward the front. **Do NOT OVERFIRE THE FIREPLACE.** Overfire conditions may be created by large amounts of kindling, building scraps, or other improper fuels.

Ashes, important because they form a bed of glowing coals, should only be left to accumulate within an inch or two of the bottom of the grate. Excess ashes can be used to check a flaming fire; or to "bank" your fire, cover the logs with ashes. A "banked" fire will hold glowing coals for 8-10 hours, thereby saving a fire for later use.

WOOD VS. FOSSIL FUELS

Compared to fossil fuels, a full cord of dry hickory weighs about two tons and is approximately equal in heating value to a ton of hard coal. On a pound basis, heavy hardwoods have about half the heating value of coal. The tabulation shows the relative densities and heat values of a variety of dry woods. Varieties at the top of the list (Dogwood) burn longer and those near the bottom (White Pine) ignite and burn quicker. A combination of both light and heavy wood is desired.

<u>SPECIES</u>	<u>DENSITY</u>	<u>HEAT VALUE</u>	<u>SPECIES</u>	<u>DENSITY</u>	<u>HEAT VALUE</u>
Dogwood	.70-.79	100-107	Ash	.57-.61	81-82
Hickory	.70-.74	100	Southern Pine	.51-.60	73-81
Oak	.60-.73	86-99	Elm	.50-.59	71-80
Black Locust	.69-.70	95-98	Cherry	.50-.52	70
Beech	.64-.66	89-91	Douglas Fir	.45-.51	64-69
Hard Maple	.58-.65	83-88	Spruce	.41-.44	59
Birch	.55-.64	79-86	Redwood	.33-.40	47-54
Apple	.58-.62	83-84	White Pine	.35-.37	50

A FEW WORDS OF CAUTION

Beware of burning certain material in your fireplace. Among these are plastics, poison ivy twigs and stems, and chemically treated woods such as discarded poles and railroad ties. These not only create air pollution, but can induce extreme irritation for some individuals.

Use hemlock, spruce, juniper and other resinous woods with caution. They contain moisture pockets which, upon heating, "pop" with considerable vigor.

Always use a fire screen. And always "bank" a fire, or at least push all unburned fuel to the rear of the grate before leaving a fire unattended. Do not use this fireplace as an incinerator.

Because the termination of the chimney above the roof is exposed to wind and cold and the pressure changes these and other environmental conditions may cause, a sufficient chimney draft may be hard to establish at times. At other times the draft may be sufficiently disrupted to cause smoke to spill from the fireplace opening. If problems with chimney draft occur, help start chimney draft before you build a fire by holding a piece of burning paper near the flue opening at the top of the firebox to preheat the chimney. If smoke spills from the fireplace opening after the fire is burning, open a window on the up wind side of the house that is far enough away from the fireplace that the wind will not blow across the fireplace opening, push the burning wood as near the back of the fireplace as possible, and if the fireplace is equipped with glass doors, close them.

DO NOT LEAVE CHILDREN OR PHYSICALLY OR MENTALLY HANDICAPPED, OR SENILE PERSONS ALONE WITH A BURNING FIREPLACE.

MAINTENANCE AND SAFETY

FUEL STORAGE

Wood can be dried sufficiently for burning within a few weeks if protected from rain in a low humidity area. It is far better to cut wood and allow it to dry for a year. In all cases, the wood should be stacked so that both ends of the sticks are exposed to the air and protected from rain. The drier the wood, the more usable heat produced by the fire and less likely rapid accumulation of soot and creosote within the chimney is to occur. See the section of this manual concerning chimney maintenance for information concerning the hazards of soot and creosote accumulation. Small quantities of wood required for fire tending must be kept at least 30 inches from the fireplace.

DISPOSAL OF ASHES

Ashes should be placed in a metal container with a tight fitting lid. The closed container of ashes should be placed on a noncombustible floor or on the ground well away from all combustible materials pending final disposal. If the ashes are disposed of by burial in soil or otherwise locally dispersed, they should be retained in the closed container until all cinder has thoroughly cooled. Ashes should never be placed in a container with combustible materials.

CHIMNEY MAINTENANCE

Creosote, Formation and Need for Removal: When wood is burned slowly, it produces tar and other organic vapors, which combine with expelled moisture to form creosote. The creosote vapors condense in the relatively cool chimney flue of a slow-burning fire. As a result, creosote residue accumulates on the flue lining. When ignited, this creosote makes an extremely hot fire.

The chimney should be inspected at least twice a year during the heating season to determine if a creosote buildup has occurred.

If creosote has accumulated it should be removed to reduce the risk of a chimney fire.

The chimney cap can be removed for inspection, maintenance and cleaning by removing three screws from the support legs and lifting upward.

When the fireplace is first in use, inspect the chimney frequently and clean the chimney any time an accumulation is observed on the flue walls. The frequency of these inspections can be increased or reduced appropriately after a pattern of accumulation has been established. Please note, however, that changes in the outside environmental conditions such as temperature and humidity or changes in the operation of the fireplace can lead to rapid buildup of soot and/or creosote.

To clean the chimney, obtain the services of a qualified and reputable chimney sweep, or remove the accumulation with brushes on wooden or fiberglass poles. Do not use metal pipes, chains, wires, etc., to clean the chimney because such items can scratch the surface of the stainless steel flue which can shorten the life of the flue and provide a rough surface for soot particles to attach to.

Be sure to cover nearby furnishing and arrange some method of catching soot and creosote particles that may fall during the chimney cleaning process. If glass doors are installed on the fireplace, they should be closed. Extra caution must be used to avoid damage to the flue damper during the cleaning process.

In addition to checking and cleaning the chimney on a regular basis, be sure to inspect the chimney before starting a fire at the beginning of each heating season. Make sure the chimney is clear from any accumulation of soot, creosote or any other debris, and that all joints are intact.

Monessen Hearth Systems does not recommend chemical cleaners because some may contain elements that corrode the metal parts of the chimney or fireplace.

MAINTENANCE AND SAFETY

FIREPLACE MAINTENANCE

At the end of each heating season or when the fireplace will not be in use for an extended time, the ashes should be removed and the hearth area should be swept as clean as is practical. The slow absorption of moisture into the ashes over a long period of time could cause a condition which would be corrosive to the metal fireplace parts.

At the beginning of each heating season, always operate the flue damper and make sure it has not become stuck from soot, creosote, etc., during the period of inactivity.

Keep the lower and upper grille panels clean and free from dirt and lint accumulation at all times to get the maximum efficiency from your fireplace.

As you use the fireplace, expansion and contraction will cause minor cracking of the hearth, back, and side refractory materials. This is normal and unavoidable. If the cracks become large enough or parts dislodge and metal behind the refractory is exposed, the refractory panels should be replaced with new panels that can be obtained from your fireplace dealer.

GLASS DOOR MAINTENANCE

For glass door maintenance, see instructions provided with the glass doors.

CHECKLIST OF DO'S AND DONT'S

DO'S

1. Do check with local building officials to be sure the installation of the fireplace complies with all building codes and requirements and obtain required building permits. Do plan your installation with safety as your primary consideration.
3. Do use only the prescribed material and parts for the installation of the fireplace.
4. Do insulate the exterior walls surrounding the fireplace to prevent excessive heat loss from the fireplace.
5. Do trim the face of the fireplace only with noncombustible materials.
6. Do attach the noncombustible face trim material firmly to the face of the fireplace.
7. Do block in or fasten the fireplace to prevent the possibility of the fireplace shifting out of position.
8. Do connect the air circulation blower to a properly grounded and fused electrical circuit.
9. Do enclose the chimney where it passes through living spaces or spaces accessible for storage purposes to prevent contact with and possible damage to the chimney.
10. Do install firestop spacers at each ceiling level when the chimney is installed in a multistory building.
11. Do install the proper chimney cap or chimney housing on the chimney to prevent rain and debris from entering the chimney.
12. Do keep all flammable liquids, gases and pressurized containers away from the fireplace.
13. Do check the fireplace for proper adjustment and operation before leaving it unattended for long periods of time.
14. Do inspect and clean the fireplace chimney regularly.
15. Do keep the fire screens closed when the fireplace is left unattended to minimize the danger of sparks popping out of the fireplace.
16. Do use the grate furnished with and for this fireplace.
17. Do start a fire only with paper, kindling or solid composition fire starters specifically designed for starting a fire. The use of liquid fire starter can cause an explosion within the fireplace.
18. Do place all ashes in a metal container with a tight fitting lid and place them on a noncombustible surface well away from other combustible materials until they have completely cooled.
19. Do store your fuel supply at a distance equal to or greater than the spacing recommended for combustible materials from the fireplace.

MAINTENANCE AND SAFETY

20. Do not build fires of moderate intensity in the fireplace for the first three fires to allow materials to adjust and cure before being subjected to the intense heat of a large fire.

DONT'S

1. Don't allow other installations or operation considerations to take priority over safety considerations.
2. Don't attempt to use the fireplace until the installation is complete.
3. Don't use unlisted parts and accessories with the fireplace except for special flashings fabricated locally.
4. Don't use damaged parts or accessories with this fireplace.
5. Don't install the fireplace in an exposed or uninsulated area.
6. Don't install the fireplace over carpeting.
7. Don't install the fireplace on a poorly constructed base or fail to fasten down or attach the fireplace to prevent it from shifting out of position.
8. Don't create or allow a crack to develop between the metal face of the fireplace and noncombustible trim.
9. Don't use power blowers or air circulation systems with this fireplace that are not specifically recommended by Monessen Hearth Systems.
10. Don't connect accessory air circulation blowers to improperly fused or ungrounded electrical circuits.
11. Don't install the fireplace where flammable or explosive liquids or vapors are likely to be present.
12. Don't neglect all the considerations mentioned in this manual concerning clearances to combustibles, spacing from obstructions and proper chimney height when selecting the location and installing the chimney.
13. Don't allow insulating materials to contact the chimney.
14. Don't neglect to apply caulking or mastic to the required joints of the flashing and between the flashing and roof.
15. Don't dry clothing or other articles near the fireplace.
16. Don't store or place flammable liquids, gases or pressurized containers near the fireplace.
17. Don't neglect to instruct all responsible persons in the proper and safe operation of the fireplace.
18. Don't fail to instruct all persons, especially children and elderly persons, concerning the hazards of improper operation and unauthorized tampering with the fireplace.
19. Don't use this fireplace to burn paper, cardboard, or other debris.
20. Don't neglect to inspect and clean the chimney regularly.
21. Don't operate the fireplace with the glass fire screen doors partially open. The doors should always be fully open or fully closed.
22. Don't use gasoline, kerosene, engine oil, charcoal lighter fluid, or other flammable liquids to start or intensify a fire. Using these and similar materials can cause an explosion within the fireplace.
23. Don't store fuel supply closer to the fireplace than the minimum spacing required for combustible materials.
24. Don't subject the fireplace to the intense heat of a large fire the first three times the fireplace is used, but build moderate fires to allow the materials to cure and adjust.
25. Don't clean the chimney with metallic devices or chemical cleaners.
26. Don't use the fireplace or chimney for venting wood or coal burning heaters or inserts unless approved in writing by Monessen Hearth Systems.
27. Don't put combustibles within 24 inches of the fireplace opening

"WARNING: IF NOT INSTALLED, OPERATED AND MAINTAINED IN ACCORDANCE WITH THE MANUFACTURERS INSTRUCTIONS, THIS PRODUCT COULD EXPOSE YOU TO SUBSTANCES IN FUEL OR FROM FUEL COMBUSTION WHICH CAN CAUSE DEATH OR SERIOUS ILLNESS AND WHICH ARE KNOWN TO THE STATE OF CALIFORNIA TO CAUSE CANCER, BIRTH DEFECTS OR OTHER REPRODUCTIVE HARM. ALSO, OPERATION, INSTALLATION AND SERVICING OF THIS PRODUCT COULD EXPOSE YOU TO AIRBORNE PARTICLES OF GLASS WOOL FIBERS KNOWN TO THE STATE OF CALIFORNIA TO CAUSE CANCER THROUGH INHALATION."

REPAIR PART DIAGRAMS AND LISTS

All repair part orders should be placed through your local dealer. To ensure prompt and accurate service, please provide the following information when placing a repair part order: Model number of your Appliance, Part Name, Part Number, and Quantity of parts needed.

Technical Service Department
2813 W. Mall Drive, Unit B.
Florence, Alabama 35630.
Tel. - 1-866-500-5671
www.monessenhearth.com

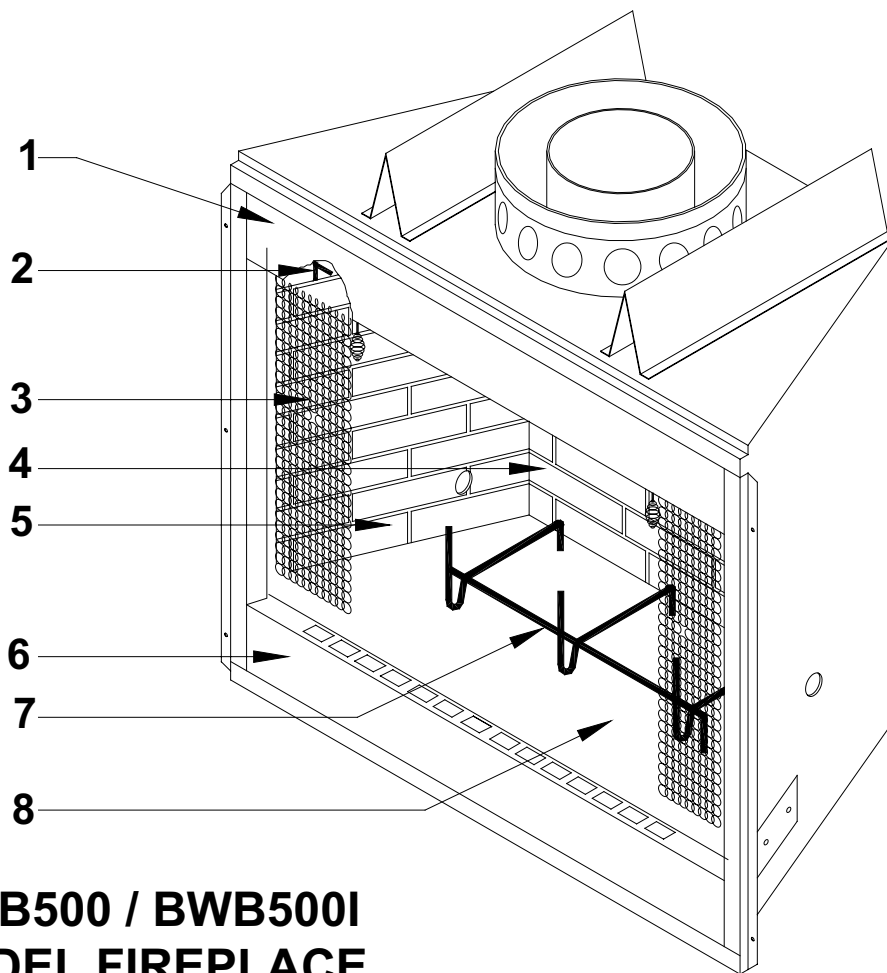

BWB500 / BWB500I MODEL FIREPLACE

KEY NO.	PART NAME	QTY.	PART NUMBER
1	UPPER PANEL PNTD. ASSY.	1	077072
2	WELDMENT AIR DOOR ROD	1	031867
3	FIRESCREEN PANELS	2	070874
4	FIREBRICK BACK ASSY.	1	034820
5	FIREBRICK SIDE ASSY.	2	035493
6	LOWER PANEL PNTD. ASSY.	1	077068
7	GRATE PNTD. ASSY.	1	035326
8	HEARTH REFRACTORY ASSY.	1	035018

REPAIR PART DIAGRAMS AND LISTS

All repair part orders should be placed through your local dealer. To ensure prompt and accurate service, please provide the following information when placing a repair part order: Model number of your Appliance, Part Name, Part Number, and Quantity of parts needed.

Technical Service Department
2813 W. Mall Drive, Unit B.
Florence, Alabama 35630.
Tel. - 1-866-500-5671
www.monessenhearth.com

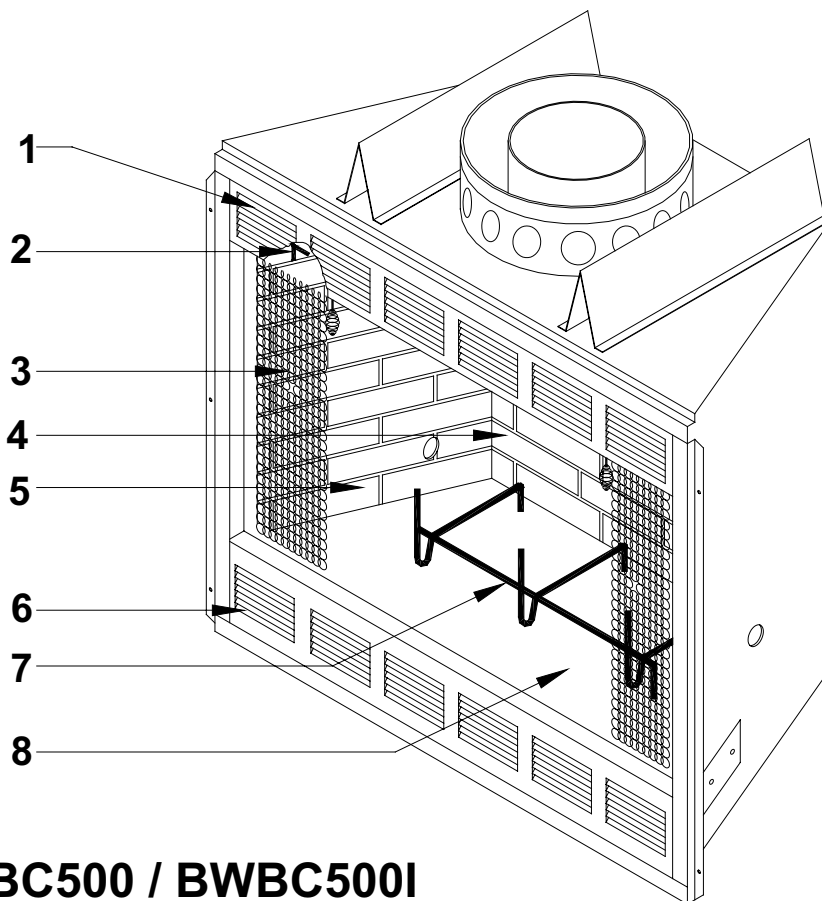

BWBC500 / BWBC500I MODEL FIREPLACE

KEY NO.	PART NAME	QTY.	PART NUMBER
1	UPPER GRILLE PNTD. ASSY.	1	077078
2	WELDMENT AIR DOOR ROD	1	031867
3	FIRESCREEN PANELS	2	070874
4	FIREBRICK BACK ASSY.	1	034820
5	FIREBRICK SIDE ASSY.	2	035493
6	LOWER GRILLE PNTD. ASSY.	1	077075
7	GRATE PNTD. ASSY.	1	035326
8	HEARTH REFRACTORY ASSY.	1	035018

FACTORY-BUILT FIREPLACE AND COMPONENTS (EXCEPT BLOWERS)

WHAT IS COVERED AND FOR HOW LONG

- **FIVE-YEAR COVERAGE** - For five years from the date this fireplace and components are first purchased for use, Monessen Hearth Systems will, at its option, repair or replace any defective part of this fireplace or components, or refund to you a sum not to exceed the factory retail price in effect at the time of purchase.
- **TEN-YEAR COVERAGE** - From the sixth through the tenth year following the date this fireplace or accessory is first purchased for use, Monessen Hearth Systems will make available to you, at our factory, a free replacement for any defective part in this fireplace or accessory.
- **TWENTY-FIVE-YEAR AVAILABILITY OF REPLACEMENT PARTS** - From the eleventh through the twenty-fifth year following the date this fireplace or accessory is first purchased for use, Monessen Hearth Systems will make available at our factory replacement parts for this fireplace or accessory, which you may purchase for the list price current at the time your purchase order is received.

WHAT IS NOT COVERED

This limited warranty does not cover:

- Transportation or shipping cost.
- The cost of a service call to diagnose trouble.
- Painted surfaces.
- Damage or defect caused by improper installation, accident, misuse, abuse or alteration.
- Poor ventilation of smoke or gases caused by air-conditioning and heating systems, exhaust fans, or pressure differentials produced by wind.
- Broken glass components
- Cracks in ceramic and castable parts that do not affect safe operation.
- We do not warrant this fireplace to be in compliance with your local building code. Building codes vary greatly throughout the country, and you should determine whether your local building code contains restrictions on the use of this fireplace before you purchase it.
- Blowers or fans, which are warranted separately.
- Heat loss due to the passage of heat or air through or around the fireplace.

Also, under our five year coverage, we do not pay the cost of removal and replacement of any portion of the structure in which the fireplace is situated, made necessary by the repair, removal or re-installation of the fireplace.

And under our twenty-five year warranty of availability of replacement parts, we only promise to maintain a supply of replacement parts at our factory for you to purchase.

LIMITATIONS AND EXCLUSIONS

1. No one has authority to add to or vary this limited warranty, or to create for Monessen Hearth Systems any other obligation of liability in connection with this fireplace and accessory.
2. Monessen Hearth Systems SHALL NOT BE LIABLE FOR INCIDENTAL, CONSEQUENTIAL, SPECIAL OR CONTINGENT DAMAGES YOU MIGHT SUFFER AS A RESULT OF ITS BREACH OF THIS WRITTEN WARRANTY OR ANY IMPLIED WARRANTY. Some states do not allow the exclusion of limitation of incidental or consequential damages, so the above limitations may not apply to you.
3. This warranty applies only to the original purchaser of the fireplace or to the original owner of the dwelling when the fireplace is installed in a new dwelling and may not be transferred.
5. This warranty applies only to a fireplace sold and used in the United States.

LIMITED WARRANTY

YOUR DUTIES

This fireplace must be installed by a qualified installer according to your local building codes and installation instructions and operated according to the owner's instructions. You must keep an invoice, canceled check or payment record to verify the purchase date of the fireplace.

IF YOU HAVE A PROBLEM WITH YOUR FIREPLACE OR COMPONENT

1. Contact your nearest dealer. If you cannot locate your dealer, call or write Monessen Hearth Systems as indicated below.
2. If you do not receive satisfactory service from the dealer within a reasonable time, write Monessen Hearth Systems and include the date you purchased your fireplace or component, its serial number, and details of the problem you are having.

**Technical Service Department
2813 W. Mall Drive, Unit B.
Florence, Alabama 35630.
Tel. - 1-866-500-5671
www.monessenhearth.com**

This warranty gives you specific legal rights, and you may also have other rights which vary from state to state.

THIS PAGE INTENTIONALLY LEFT BLANK.

THIS PAGE INTENTIONALLY LEFT BLANK.

ATTENTION

APPLIANCE

INSTALLER

**PLEASE RETURN THIS OPERATING
AND INSTALLATION INSTRUCTIONS
TO THE CONSUMER.**